



EWI 4000s
ELECTRIC WIND INSTRUMENT

AKAI
professional



Operator's Manual

WARNING

To prevent fire or shock hazard,
do not expose this appliance to
rain or moisture.



THE SYMBOLS ARE RULED BY UL STANDARDS (U.S.A.)

IMPORTANT SAFETY INSTRUCTIONS

1. Before you operate the EW14000s, read these instructions.
2. Keep these instructions.
3. Heed all warnings.
4. Follow all instructions.
5. Do not use this apparatus near water.
6. Clean only with dry cloth.
7. Do not block any ventilation openings. Install in accordance with the manufacturer's instructions.
8. Do not install near any heat sources such as radiators, heat register, stoves, or other apparatus (including amplifiers) that produce heat.
9. Do not defeat the safety purpose of the polarized or grounding-type plug. A polarized plug has two blades with one wider than the other. A grounding type plug has two blades and a third grounding prong. The wide blade or the third prong is provided for your safety. If the provided plug does not fit into your outlet, consult an electrician for replacement of the obsolete outlet.
10. Protect the power cord from being walked on or pinched particularly at plugs, convenience receptacles, and the point where they exit from the apparatus.
11. Only use attachments/accessories specified by the manufacturer.
12. Use only with the cart, stand, tripod, bracket, or table specified by the manufacturer, or sold with the apparatus. When a cart is used, use caution when moving the cart/apparatus combination to avoid injury from tip-over.

PORTABLE CART WARNING



S3125A

13. Unplug this apparatus during lightning storms or when unused for long periods of time.
14. Refer all servicing to qualified service personnel. Servicing is required when the apparatus has been damaged in any way, such as power-supply cord or plug is damaged, liquid has been spilled or objects have fallen into the apparatus, the apparatus has been exposed to rain or moisture, does not operate normally, or has been dropped.
15. Do not expose this apparatus to dripping or splashing and ensure that no objects filled with liquids, such as vases, are placed on the apparatus.
16. Use only with the specified AC Adaptor.

WARNING

The EW14000s is designed to be used in a standard household environment.

Power requirements for electrical equipment vary from area to area. Please ensure that your AC Adaptor supplied meets the power requirements in your area. If in doubt, consult a qualified electrician or AKAI professional dealer.

FCC WARNING

This equipment has been tested and found to comply with the limits for a Class B digital device pursuant to Part 15 of the FCC rules. These limits are designed to provide reasonable protection against harmful interference in a residential installation.

This equipment generates, uses, and can radiate radio frequency energy and, if not installed and used in accordance with the instructions, may cause harmful interference to radio communications. However, there is no guarantee that interference will not occur in a particular installation. If this equipment does cause harmful interference to radio or television reception, which can be determined by turning the equipment off and on, the user is encouraged to try to correct the interference by one or more of the following measures:

- Reorient or relocate the receiving antenna.
- Increase the separation between the equipment and receiver.
- Connect the equipment into an outlet on a circuit different from that to which the receiver is connected.
- Consult the dealer or an experienced radio/TV technician for help.

CAUTION

To prevent electric shock, do not use this polarized AC power plug with an extension cord, receptacle, or other outlet unless the blades can be fully inserted to prevent blade exposure.

Afin d'éviter tout risque de décharge électrique, n' utilisez pas cette prise polarisée avec une rallonge, une prise de courant ou autre sortie à moins que les lames puissent être complètement insérées et qu'elles ne soient plus visibles.

Changes or Modifications not expressly approved by the manufacturer for compliance could void the user's authority to operate the equipment.

This appliance is not equipped with a main power switch. Even when the appliance is turned off, the power supply to the appliance is not completely turned off when the power cord is plugged in. Pull out the adaptor when not using the appliance for long periods.

This digital apparatus does not exceed the Class B limits for radio noise emissions from digital apparatus set out in the Radio Interference Regulations of the Canadian Department of Communications.

AVIS POUR LES ACHETEURS CANADIENS DU EWI4000s

Le présent appareil numérique n'émet pas de bruits radioélectriques dépassant les limites applicables aux appareils numériques de la Class B prescrites dans le Règlement sur le brouillage radioélectrique édicté par le ministère des Communications du Canada.

Table of Contents

Chapter1: Introduction	1
FEATURE	1
Part's names and Functions	2
Top Panel	2
Side / Rear Panel	3
A: Program/Data Display part.....	4
B: Glide Plate part.....	4
C: Bend Plate part	5
D: Power/MIDI/Audio Out part	6
E: Cable Clutch part	6
Precautions	7
How to install the Batteries	7
AC adapter.....	7
Connections	8
Connections from Line Out of the EW14000s to a Mixer or keyboard amplifier	8
Connections from Headphone Out of the EW14000s to the Headphones	8
Connections from Line out of the EW14000s to the wireless system	9
Removing the Cable Clutch	9

Chapter2: Basic Operation **10**

About the EW14000s10

Basic Operations11

How to hold the EW14000s.....11

Operating the Note keys11

Octave Shift Rollers11

Earth Plates11

Mouthpiece12

Vibrato12

Tonguing12

Bend UP/DOWN13

Glide13

Hold and OCT buttons13

Sensor Sensitivity Adjustment14

Adjusting the Breath Sensor15

Adjusting the Bend Effect16

Adjusting the Vibrato Effect17

Adjusting the Glide Effect17

Adjusting the Touch Sensor Sensitivity18

Chapter3: Playing EWI4000s with Internal sounds 26

Selecting the Internal Sounds (Program)	20
Selecting the Internal Sounds (Program)	20
Assigning a Program number to the key note	20
Recalling the Program number assigned to a key note	22
Alternate way of Selecting the Program number	23
Program Up with the [HOLD] button	23
Program Down with the [OCT] button	24
Adjusting the Volumes for the Sound / Effect	25
Adjusting the Main Volume	25
Adjusting the volume of each Program.....	25
Adjusting the Reverb Volume	26
Adjusting the Reverb effect volume of each program	26
Adjusting the Delay effect volume of each program	27
Adjusting the Chorus effect on/off on each program	28
Octave Funtion (OCT button)	29
Setting the Octave function to OCT button	29
Hold Funtion (OCT button)	30
Setting the Hold function to HOLD button	30
Selecting “Time” or “Rate” on the Glide effect	31
Adjusting the Key Delay	32

Transpose function	33
Setting the Transpose function	33
Tuning	34
Editing the internal sound by using the computer	35

Chapter4: Using the EWI4000s as a MIDI Controller 36

About MIDI	36
To use the EWI4000s as a MIDI Controller, you will need the following	37
Connection	37
Setting of the external MIDI sound module	37
Setting of the EWI4000s	38
Program Change	36

Using the EWI4000s as a MIDI controller (Application)39

Changing the MIDI Channel.....	39
Changing the Breath sensor output.....	40
Setting the MIDI Velocity value.....	42
Changing the Vibrato Sensor output to another MIDI event	43
Octave function (OCT button) on MIDI Transmit	44
Hold function (HOLD button) on MIDI Transmit	44
Setting the Hold function	44
Selecting Portamento ON/OFF while touching the Glide plate	45

Initialize to Factory Preset 46

Specifications	47
EWI4000s Standard Fingering Charts	48
MIDI Implementation Charts	51
Trouble Shooting	52

Chapter 1 Introduction

We greatly appreciate your purchase of the AKAI professional Electric Wind Instrument EWI4000s. The EWI4000s is an electric wind controller equipped sound module. This manual includes detailed explanations of operations, etc. designed to show you how to use the superior functions of the EWI4000s to its fullest extent.

FEATURES

- The EWI4000s is a controller that allows you to play the same way as you would play a woodwind instrument such as the saxophone, clarinet, etc.
- Special sensors that detect the intensity of the breath and the pressures applied to the mouth-piece make it possible to sensitively control the pitch, tone, and volume, allowing the players' emotions to be articulated directly.
- The EWI4000s includes touch plates that give you Pitch Bend or Glide effect easily, as well as Octave Shift rollers that enable you to shift over an 8 octave range.
- The EWI4000s' touch sensor keys allow you to perform quickly.
- The EWI4000s has an analog-modeling synthesizer with 2 VCOs and 2 VCFs inside.
- The EWI4000s is equipped with not only an internal sound module, but also with internal effects such as Reverb, Delay, and Chorus. You can play the EWI4000s simply by connecting an audio cable to an amplifier, without need for an external sound/FX module.
- The EWI4000s can be powered with batteries (4 AA batteries). If you use a wireless system with it, you can play it without a cable.
- The EWI4000s allows you to change the instrument's preset sound, the output level, and the effect level.
- The EWI4000s can trigger an external MIDI sound module by connecting a MIDI cable to the external device's MIDI IN port.
- You can download free sound editing software for the EWI4000s from our web site (<http://www.akaipro.com>). This software allows you to edit the internal preset sounds and the internal effect's parameter.
- The EWI4000s has a headphone output, so you can practice with headphones, avoiding the disturbance of others.

Parts' Names and Functions

This chapter describes the name of each part and its function.

■ Top Panel

Hold Button: This button is used to go into HOLD mode or works as the Program Up function. Pressing this button turns the LED on and enables the specified function. It also works as “+”(Increase) button in Setup mode.

Octave Button : This button is used to activate the OCTAVE mode or works as the Program Down function. Pressing this button turns the LED on and enables the specified function. It also works as “-”(Increase) button in Setup mode.

MOUTH PIECE: Hold the tip of the Mouthpiece and blow to play-much like a traditional woodwind instrument. There is vibrato sensor in the Mouthpiece. You can produce a vibrato effect by gently biting the Mouthpiece. Do not bite too hard.

Note Keys (with Touch Sensors): These keys decide the note. The three low keys can be adjusted the finger position by loosening its screw.

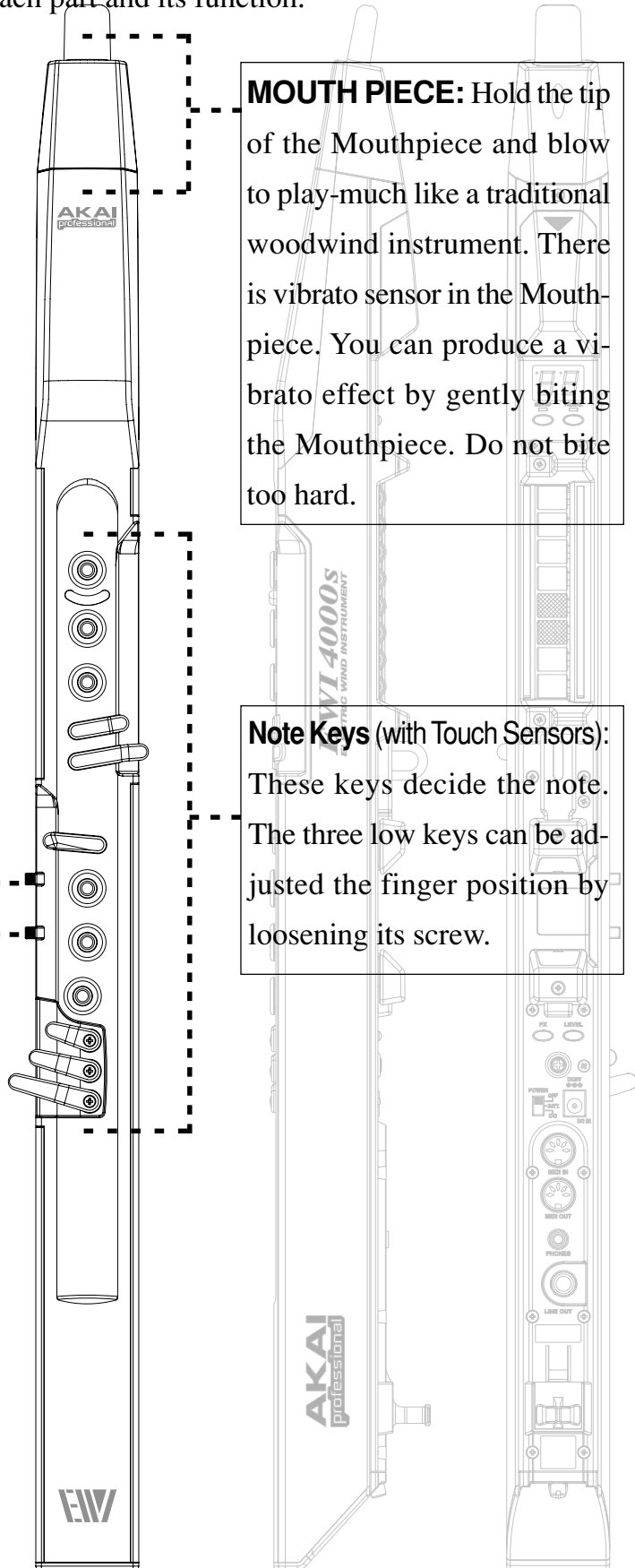

Side / Rear Panel

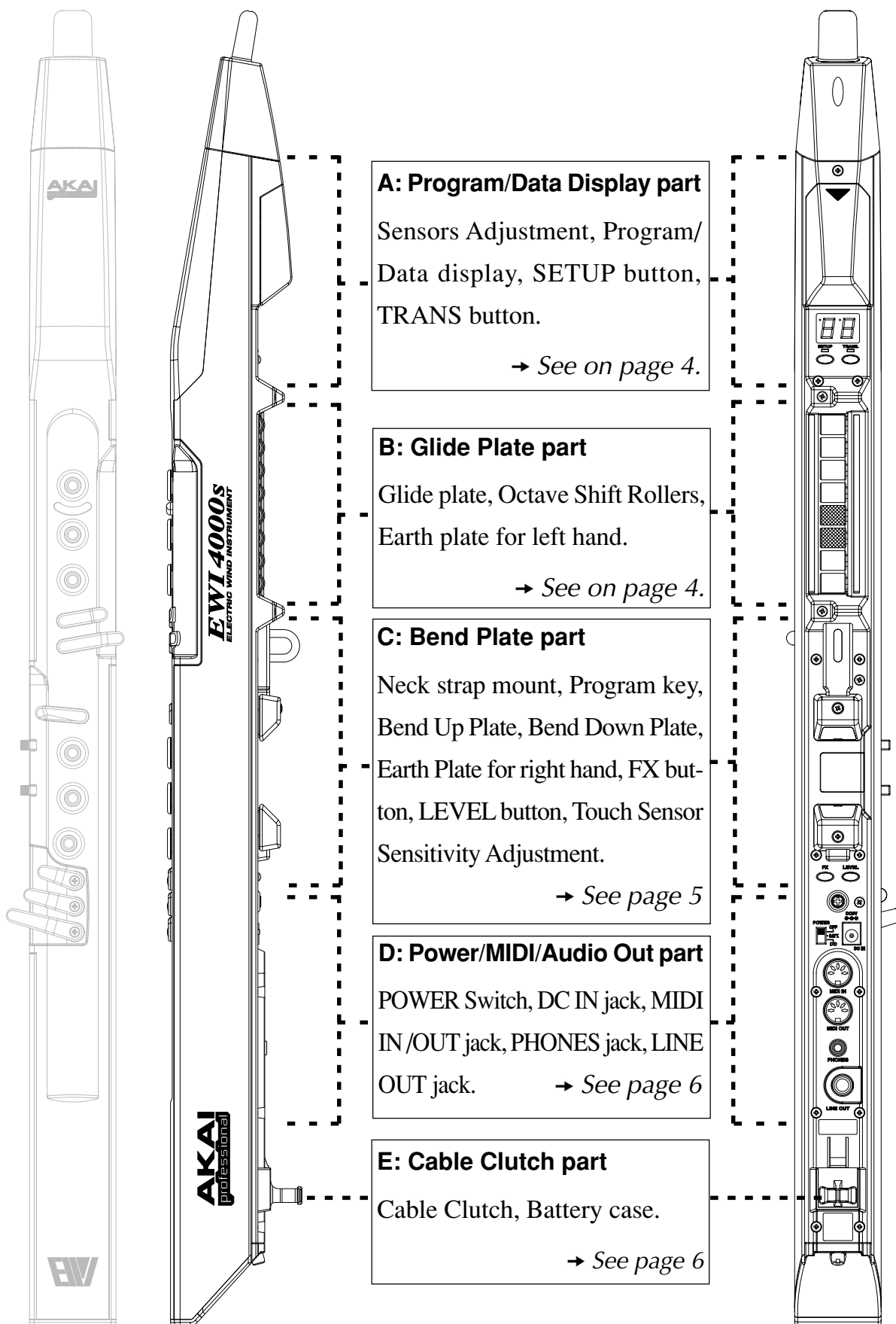

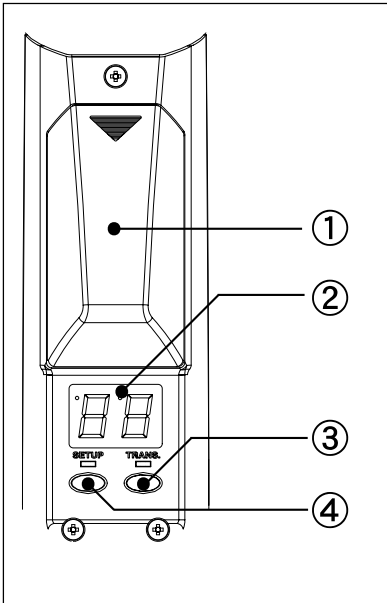

A: Program/Data Display part

(1) Sensor Adjustment

There are 7 knobs for each Sensor Adjustment behind the Cover. See the Sensor adjustment on page 14.

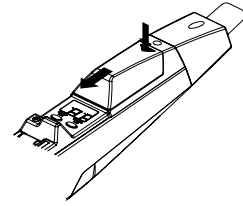

(2) Program/Data Display

It shows the Program number or the setting value.

(3) TRANS (Transpose) button

It selects the Transpose function ON/OFF. When the transpose function is selected, the LED is lit up. You can set the transpose value by using the [HOLD] or the [OCT] button while pressing the [TRANS] button.

(4) SETUP button

Press this button to enter Setup mode. The LED is lit up when you are in setup mode.

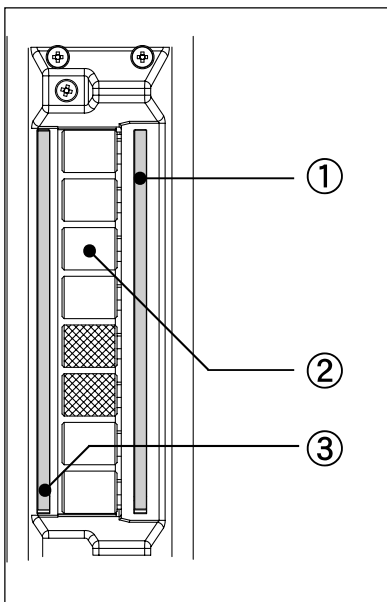

B: Glide Plate part

(1) Glide Plate (with a touch sensor)

Touching this plate produces a Glide effect (smoothly and continuously slides the pitch up or down: Portamento)

(2) Octave Shift Rollers (with touch sensors)

They shift the basic range played by Note Keys over 8 octaves. Always touch these rollers while playing.

(3) Earth plate for left hand

Always keep either your thumb on the Earth plate while playing.

C: Bend Plate part

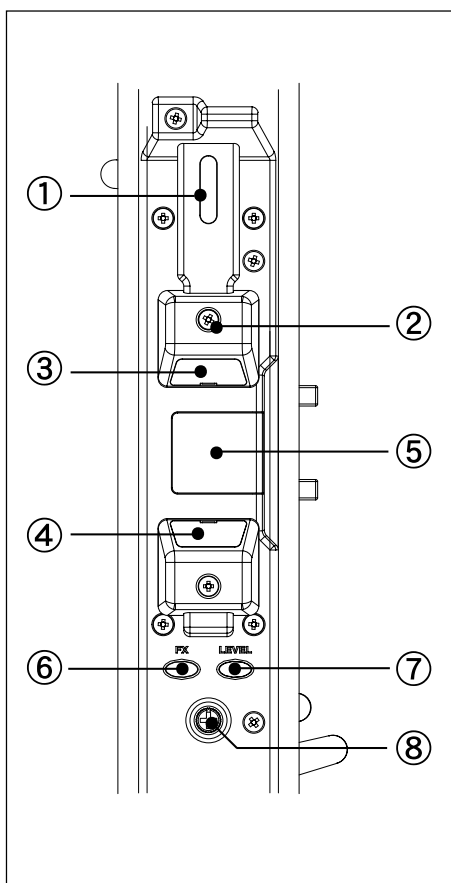

(1) Neck strap Mount

Hang the EWI4000s on a Neck strap (included) to make your playing easier.

(2) Program key (with a touch sensor)

It changes the Program (internal sound). By touching this key without touching any note keys, the selected Program number is shown on the Program/Data display, and then you can change the Program number by using the [HOLD] or the [OCT] button.

(3) Bend Up Plate (with a touch sensor)

Touching this key raises the pitch. You can adjust the position of the plate by loosening its screw.

(4) Bend Down Plate (with a touch sensor)

Touching this key lower the pitch. You can adjust the position of the plate by loosening its screw.

(5) Earth Plate for right hand (with a touch sensor)

Always keep either your thumb on the Earth plate while playing

(6) FX (Effect) button

Pressing this button shows the overall Reverb level on the Program/Data display, and then you can change the level by using the [HOLD] or the [OCT] button.

(7) LEVEL button

Pressing this button shows the Main Output level on the Program/Data display, and then you can change the level by using the [HOLD] or the [OCT] button

(8) Touch Sensor Sensitivity Adjustment knob

Adjustment knob for Touch sensor keys. It is very important to set this correctly. See page 18 to set this up properly.

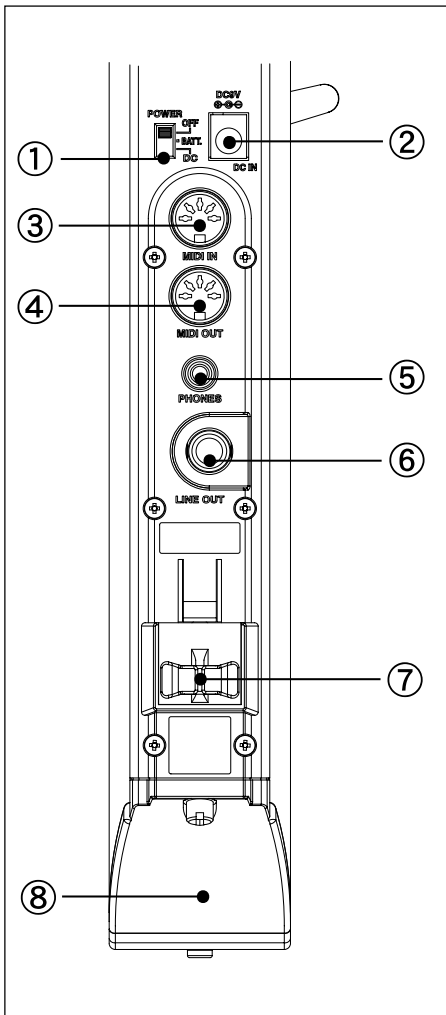

D: Power/MIDI/Audio Out part

(1) Power Switch

Select the “BATT” while using the batteries, “DC” while using the AC adaptor (MP-9, Optional). Select the “OFF” while the EWI4000s is not in use.

(2) DC IN jack

Plug the AC adaptor (MP-9, Optional) in here.

(3) MIDI IN jack

Plug a MIDI cable from the MIDI OUT of your Computer for editing the internal Sounds with the Sound Editor software

(4) MIDI OUT jack

Plug a MIDI cable from the MIDI IN of the external sound module while the EWI4000s works as MIDI Controller. Or plug a MIDI cable from the MIDI IN of your Computer for editing the internal Sounds with the Sound Editor software.

(5) PHONES jack (stereo mini jack)

Plug Head Phones in here

(6) LINE OUT jack

Plug an audio cable from the input of a Mixer or Amplifier in here.

E: Cable Clutch part

(7) Cable Clutch

Place a cable such as an Audio or MIDI cable here, by widening the cable clutch with your fingers.

(8) Battery Case Cover

By loosening its screw with a coin or screw driver, the battery Case Cover can be removed.

Precautions

Before operating the EWI4000s, please be careful of the following:

- As there is a Vibrato sensor in the Mouthpiece, when you exert pressures on the mouthpiece while playing, do not bite the mouthpiece too hard with your teeth, as this may damage your EWI4000s. Use the Mouthpiece Cover after using or while carrying the EWI4000s.
- Always touch the Earth Plate and Octave Shift Rollers when playing and editing sounds. Each of touch sensors uses the performer's body as the earth.
- It is important to keep the mouthpiece clean. The mouthpiece comes in direct contact with the inside of the performer's mouth, so take care to keep it clean before, during, and after using the EWI4000s. You can clean its outer surface with disinfectant alcohol.

■ How to install the Batteries

Please use four (4) ALKALINE AA or re-chargeable AA batteries only. Refer to the drawing for correct battery installation.

Select "BATT." on the Power Switch, when using batteries. For prolonged battery life, select the "OFF" position on the Power Switch when you're finished playing.

In the event that battery power becomes low, the dot on the LED of the Program/Data display will start blinking. Change the batteries as soon as the dot on the LED starts blinking. Install the batteries very carefully - paying close attention to the direction of them (+/- sides as shown)

Remove the batteries when you are not going to be using your EWI4000s for an extended period time. Don't use the different type batteries at the same time.

■ AC adaptor

You can also use the AC adaptor "MP-9 (Optional)", instead of batteries.

Connect the "MP-9" to the "DC IN" jack of the EWI4000s and select "DC" on the Power Switch.

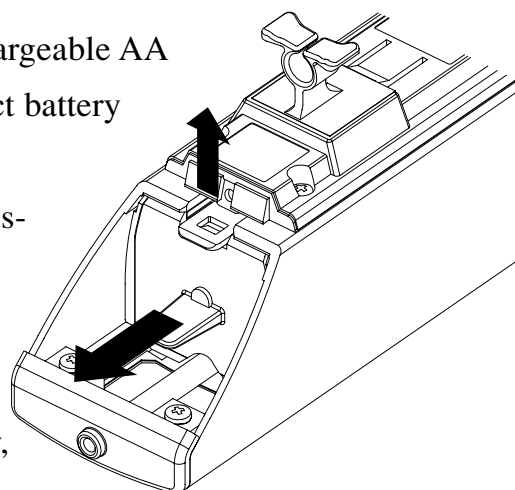

Connections

■ Connection from Line Out of the EWI4000s to a mixer or keyboard amplifier.

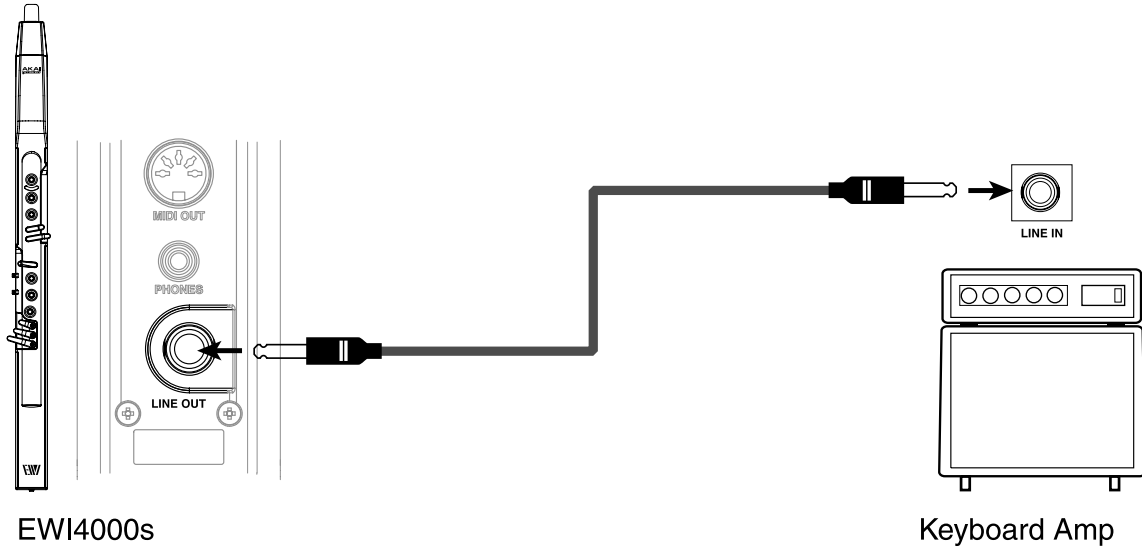

■ Connection from Headphone Out of the EWI4000s to the Headphones

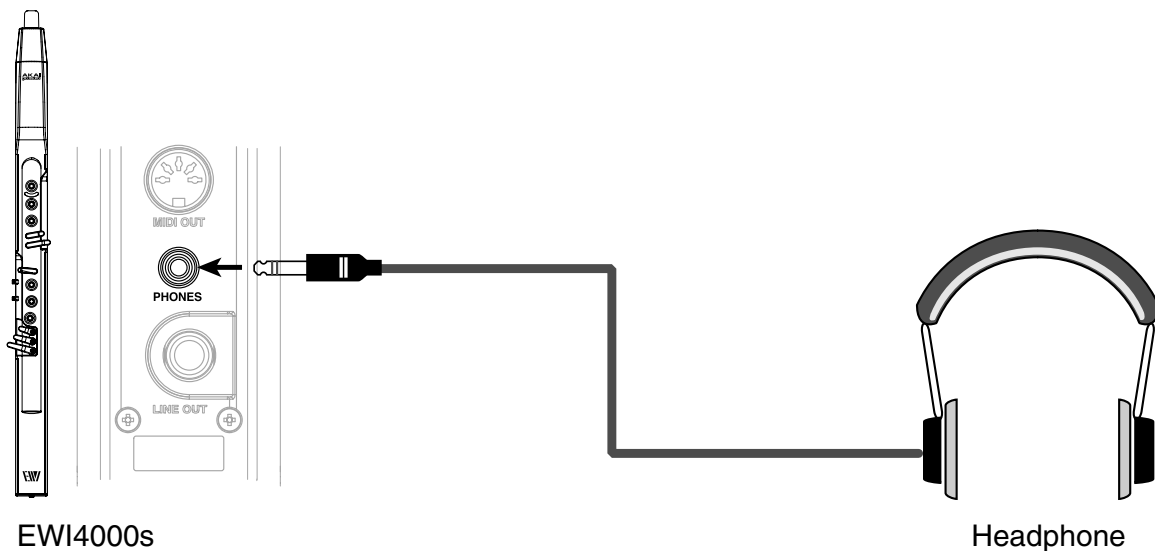

■ Connection from Line out of the EWI4000s to the wireless system

As the EWI4000s has an internal sound module, you can play it with a wireless system.

■ Removing the Cable Clutch

The Cable clutch can be removed as shown below when it interferes with using a wireless system.

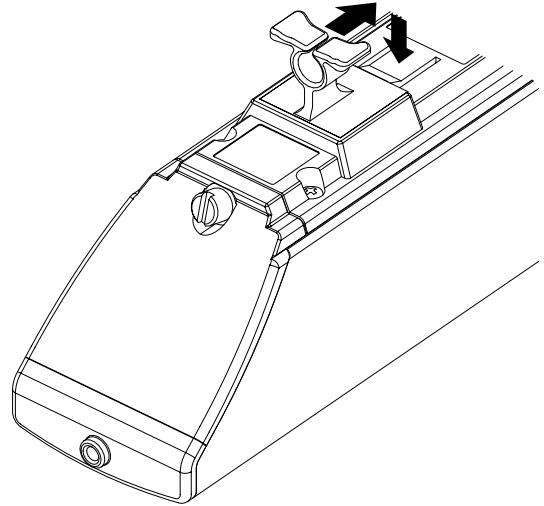

Chapter 2 Basic Operation

About the EWI4000s

The EWI4000s is a woodwind instrument MIDI type controller with an internal sound module and built-in effects. It allows you to perform powerful expressions such as an acoustic instrument and also produce the character of an electronic instrument with a wide sound and various sound colorings. The EWI4000s has an internal sound module and effects, so you can enjoy playing it simply by connecting the EWI4000s to an amplifier or headphones. In order to play the EWI4000s better, you should learn all of its functions. For example, breath power varies, from player to player, but you can adjust the Breath Sense sensitivity to accommodate.

After turning the EWI4000s on, it will be in “PLAY” mode. When you wish to adjust each Sensor’s sensitivity or adjust MIDI settings, you can change to the “SET UP” mode by pressing the [SETUP] button.

The EWI4000s has two modes: “PLAY” and “SET UP”. Once you set each Sensor as you wish, you use the “PLAY” mode for your performance.

Please take some time to read the Basic Operation before trying to play the EWI4000s.

Basic Operation

First, this explains the basic operation and adjustment of the EWI4000s.

How to hold the EWI4000s

Hold the EWI4000s the same way as you would hold a saxophone or clarinet.

The EWI4000s uses Note keys with Touch sensors. It is very useful for playing very fast passages, but it is different from the key action that is used on an ordinary wind instrument. Be sure to use the neck strap for moving your finger freely.

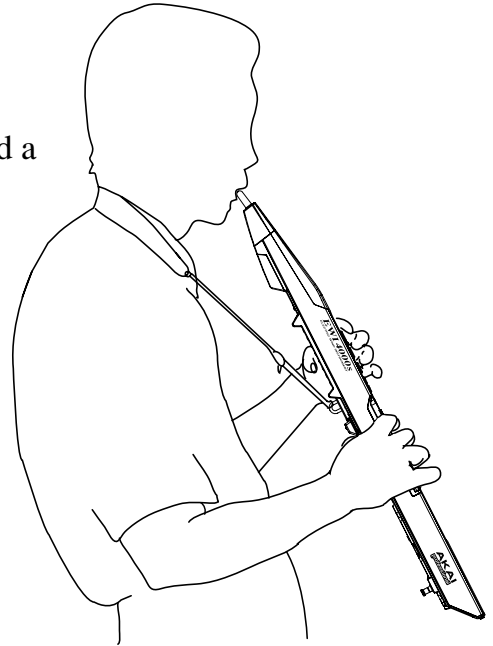

Operating the Note keys

The Note keys with touch sensors allow you to produce sound with just a light touch. Basically, the same fingering as that for a saxophone or clarinet can be used. Please refer to the “EWI4000s Standard Fingering Charts” on page 48 for details. You can also customize the EWI4000s, designing your own unique fingerings that could not exist on an acoustic sound instrument.

■ Octave Shift Rollers

Place your left thumb on the back side of the EWI4000s, between any two rollers. While playing, you must keep your left thumb touching the position between two rollers. The position between the two knurled rollers will give you standard pitch.

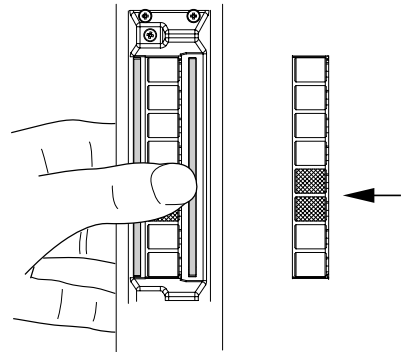

■ Earth Plates

There are two earth plates for right and left hand. Always keep either of your thumbs on the Earth Plate while playing.

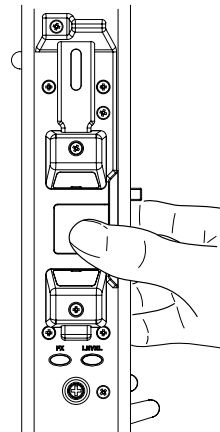

■ Mouthpiece

Hold the mouthpiece gently in your mouth with your teeth, and exhale so that the breath is passed through both ends of your mouth. The EWI4000s detects this wind pressure to the breath sensor and expresses the change in sound volume and character. The EWI4000s structure is designed so that a lot of breath is not required

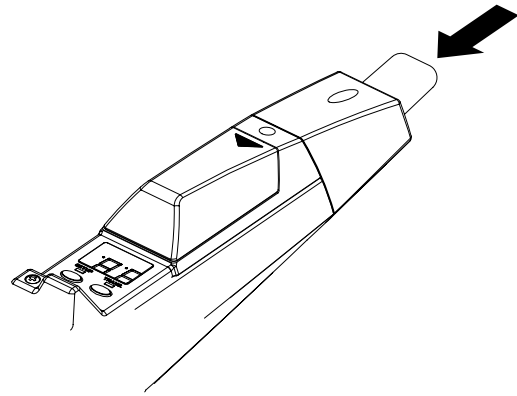

to pass through the instrument, thereby making the breathing technique for the EWI4000s unique. When you wish to play a sustained tone, you can keep a long breath and decrease the amount of air you allow to pass from each ends of your mouth. You can use various breathing techniques depending on the phrase to express powerful performances.

■ Vibrato

There is a vibrato sensor in the Mouthpiece. You can produce a vibrato effect by gently biting the Mouthpiece. Do not bite the Mouthpiece too hard with your teeth, as this may damage the Mouthpiece and the sensor inside.

■ Tonguing

You can create small bursts of air by tonguing the mouthpiece for even more expressive control.

Note: Adjust the S (Sense) knob in BR (Breath) on the EWI4000s, to create different tonguing nuances.

■ Bend UP / DOWN

By touching your thumb to the Bend up/down plate (while the Earth plate is also touched), you can obtain a pitch bend effect (moving up/down of pitch). Adjust the pitch bend range using W (Width) knob in PB (Pitch Bend) section of the EWI4000s.

Note: Before you get accustomed to these plates, you may produce unexpected sounds as the result of touching them by accident. You can also adjust the position of each Bend plate by loosening its screw.

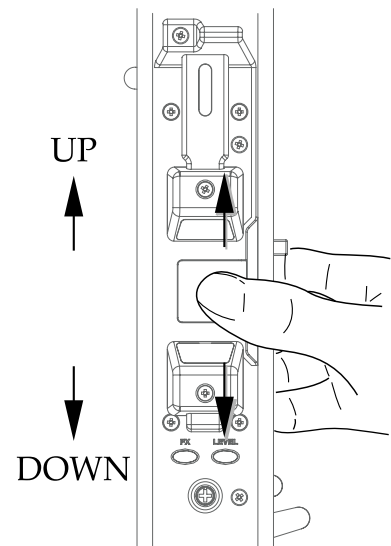

■ Glide

By moving your thumb to a position between other rollers with the Glide plate touched, you can achieve a glide effect (which will smoothly and continuously slide the pitch up or down: This is known as Portamento). Adjust the glide time using the T (Time) knob on the GL (Glide) section of the EWI4000s.

Note: Before you get used to controlling this plate, you may produce unexpected sounds by touching them accidentally.

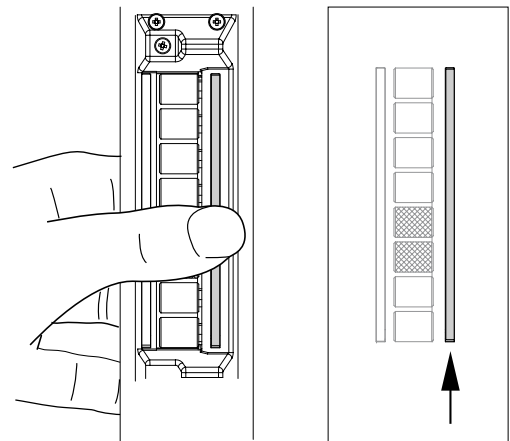

■ Hold and OCT buttons

The HOLD button enables the HOLD function (see on page 30) or Program Up function (see on page 12) in play mode. The OCT button can be set as Octave function (see on page 29) or Program Down function (see on page 24) in play mode.

While in Setup mode, the HOLD button works as a “+” and the OCT button works as a “-”.

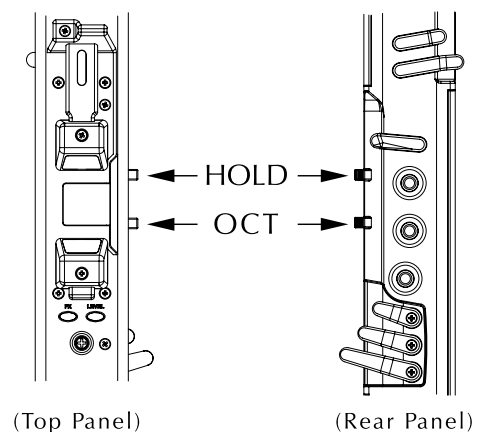

(Top Panel)

(Rear Panel)

■ Sensor Sensitivity Adjustment

To fully use the instrument’s various performance features, you should properly adjust BREATH, GLIDE, BEND, and VIBRATO sensors for your own performing requirements.

Note: Each sensor has been adjusted properly in the factory. However, adjust them again by yourself before you play it. The sensor adjustment may be changed as you prefer.

The knobs for Sensor Sensitivity Adjustment are located under the cover just above the Program/Data display. Remove the cover as shown in the drawing.

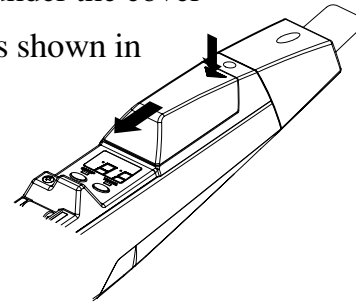

The function of each knob is as follows:

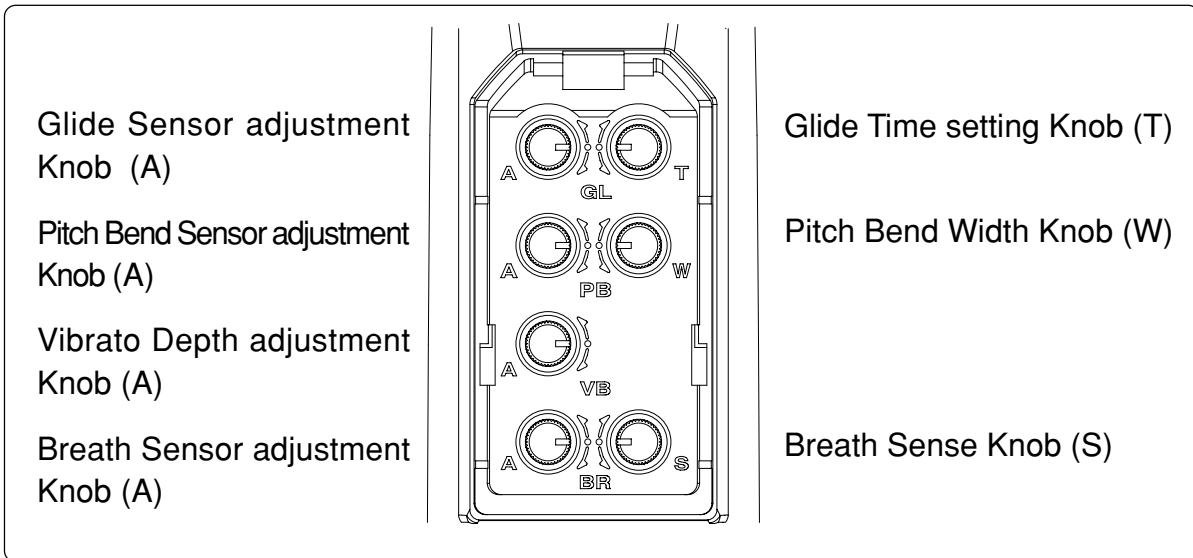

You will need to be in “SET UP” mode to adjust the Sensor Sensitivity.

1. Press the [SETUP] button
2. The LED will light up, indicating that “SET UP” mode is activated.

In the SET UP mode, each LED on the Program/Data display works as the indicator of each sensor.

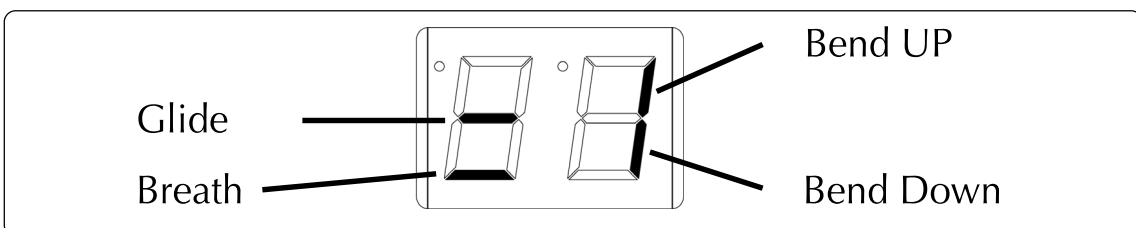

■ Adjusting the Breath Sensor

The Breath Sensor is the most important sensor for performing with emotion. It translates your breath strength and technique into sound volume and character.

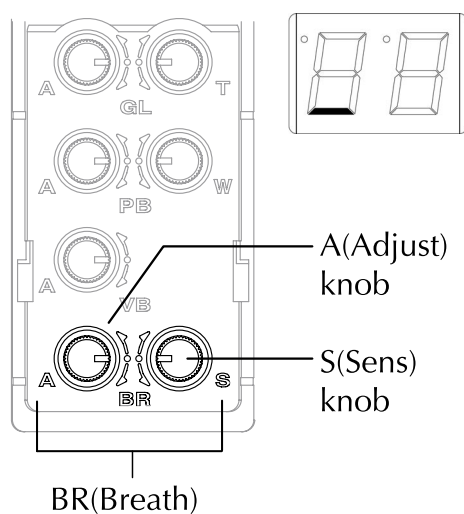

1. Set the “S” (Sensitivity) knob in the “BR” (Breath) section to the mid position, and then turn the “A” (Adjust) knob clockwise. The Breath indicator should light up. If you turn the “A” (Adjust) knob counterclockwise, it should go off.

Note: If the Breath Indicator is lit, the EWI4000s will produce sound. Be careful of the volume settings on any connected equipment while adjusting the Breath sensor.

2. Turn the “A” (Adjust) knob slowly counterclockwise from the position where the indicator is lighting up, and set it to the position where the indicator goes off.
3. Hold the EWI4000s correctly and blow into it.

The Breath sensor is properly adjusted if the sound starts when you blow, and the sound stops when you stop blowing.

4. To adjust the “S” (Sense) knob for Breath sensitivity, blow into the mouthpiece with various breath strengths, and then confirm that the output sound volume changes depending on your breath strength.

If you feel the changes by your breath strength is not sufficient enough, turn the “S” (Sense) knob counterclockwise, and then try to find the best position for you. If you feel that the changes are enough, but requires too much breath for loud sounds, turn the “S” (Sense) knob clockwise, and then try to find the best position for you.

Turning the “S” (Sense) knob clockwise allows you to trigger sound with less breath pressure, but you will have less available articulation.

Turning the “S” (Sense) knob counterclockwise will require more breath pressure to trigger sound, but you will be able to be much more expressive and articulate. Because breath pressure varies from player to player, adjust the “S” (Sense) knob to find the most comfortable position for your maximum playing expression. It may be a good idea to adjust every so often as you become more accustomed to utilizing the EWI4000s’ many features.

Note: After adjusting the S (Sense) knob, you need to adjust the A (Adjust) knob again.

■ Adjusting the Bend Effect

This adjusts the Bend sensor for Pitch Bend Up/Down (moving up/down of pitch) and sets the width of your Pitch Bends.

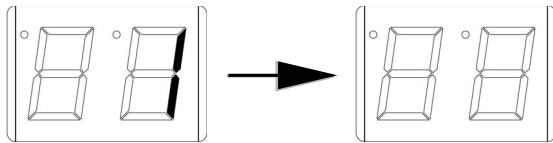
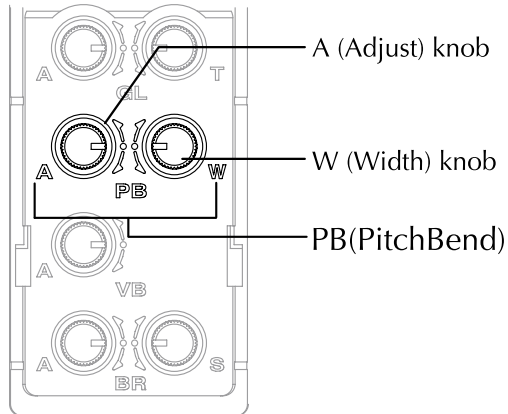

1. Set the “W” (Width) knob in the “PB” (Pitch Bend) section to full clockwise position.
2. While touching your thumb only to the Earth plate (not touching the Bend Up/Down plate), adjust the “A” (Adjust) knob in the “PB” (Pitch Bend) section so that both the UP and DOWN indicators go “OFF”.

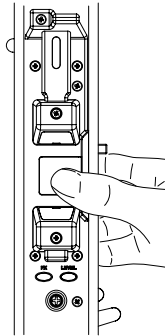

3. Hold the EWI4000s correctly and play it. The Bend Effect is properly adjusted if the pitch of the sound goes up (also the upper indicator LED lights up) when you slide your thumb to the Bend Up plate. Likewise, the pitch of the sound should go down (also the lower indicator LED lights up) when you slide your thumb to the Bend Down Plate.

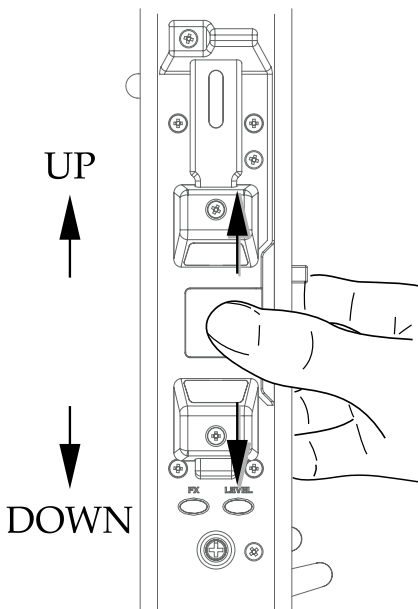

The overall change in pitch varies by how much of the plate your thumb is touching as well as the way it is touching the plate. You’ll need to experiment using the Bend UP/Down plate for best results.

If you turn the “W” (Width) knob counterclockwise, the range becomes narrower.

Note: After adjusting the W (Width) knob, you need to adjust the A (Adjust) knob again.

■ Adjusting the Vibrato Effect

By gently biting on the mouthpiece, you can produce a Vibrato effect.

Set the “A” (Adjust) knob in the “VB” (Vibrato) section to the center position.

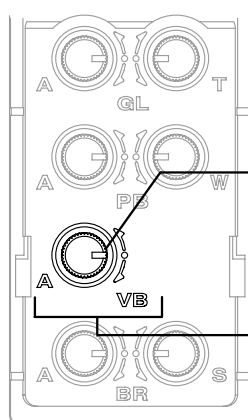

While playing the EWI4000s with a long tone, bite the Mouthpiece lightly. The sensor is properly adjusted if you get the vibrato effect while biting the Mouthpiece.

A (Adjust) knob

If you feel the vibrato effect is not set for your particular playing

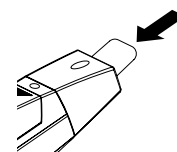

style, turn the “A” (Adjust) knob clockwise and try it again. The vibrato effect is obtained by biting the Mouthpiece many times (not just biting down on it).

■ Adjusting the Glide Effect

The Glide sensor is located to the right side of the Octave Rollers and touching it produces the Glide Effect (sliding the pitch up or down smoothly and continuously)

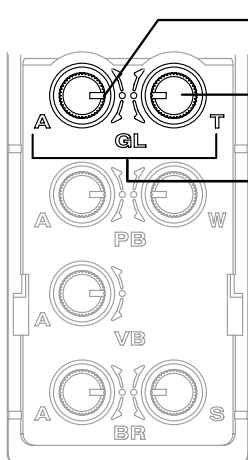

A (Adjust) knob

T (Time) knob

GL(Glide)

1. Set the “T” (Time) knob in the “GL” (Glide) section to the center position.

If you turn the “A” (Adjust) knob clockwise, the Glide indicator should light up. If you turn the “A” (Adjust) knob counterclockwise, the indicator should go off.

2. When the Glide indicator’s LED is lit, turn the “A” (Adjust) knob slightly counterclockwise until the indicator LED goes off.

3. While playing the EWI4000s, touch your thumb to both the Octave Rollers and the Glide plate. You should hear the glide effect when you change notes.

For confirming the proper setting of the Glide effect, change the Octave while playing. The pitch of the sound should slide slowly, not quickly.

If you wish to extend the slide time (longer), turn the “T” (Time) knob clockwise.

If you wish to shorten the slide time (shorter), turn the “T” (Time) knob counterclockwise.

It allows you to select either “Time” or “Rate” for the pitch shift aspect of the Glide effect.

See more information on page 31.

Note: After adjusting the T (Time) knob, you need to adjust the A (Adjust) knob again.

■ Adjusting the Touch Sensor Sensitivity

The EWI4000s uses Touch Sensor keys, not mechanical switches. In regular use, there is no need to adjust the Touch Sensor sensitivity, because it is adjusted at the factory. But it may not respond to your key touch correctly (The Program/Data display may show some numbers while in Play mode instead of showing the Program number) depending on changes in temperature, humidity or the static electricity from the floor. In this case, you will need to adjust the Touch Sensor sensitivity.

1. While in Play mode, touch the Note keys (K1, K2, K3), the earth plate, and the Octave roller with the fingers of your left hand.

(!) Don't touch the [Program] key.

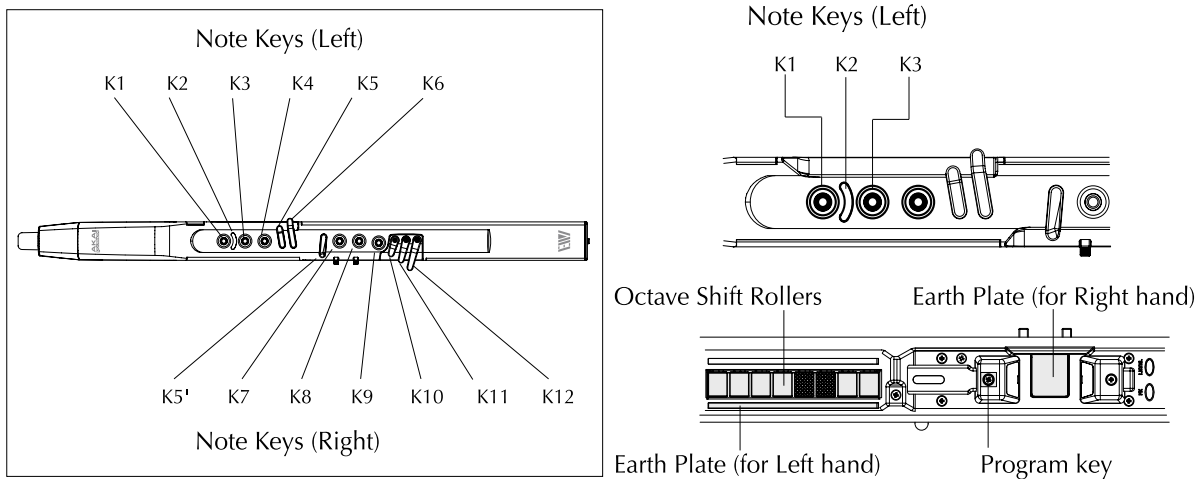

2. If there are numbers shown on the Program/Data display, turn the Touch Sensor's sensitivity volume clockwise until the numbers disappear.

If there are no numbers on the Program/Data display, turn the Touch Sensor sensitivity volume counterclockwise until numbers are shown, and then turn it clockwise until the numbers disappear, and then set to turn it a little more clockwise. Be sure that any number is not shown on the Program/Data display if you touch many keys with both your left and right hands.

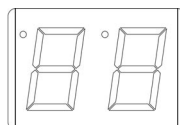
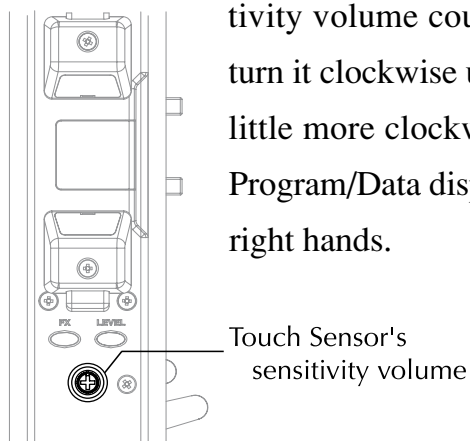

Note: You may find adjusting the sensors troublesome. But you can play a much more delicate, emotional performance if you adjust the sensors to match your style.

Once you adjust the sensors to your liking, you won't need to adjust them every time you play. As the sensor is very delicate, its sensitivity may be changed by circumstances such

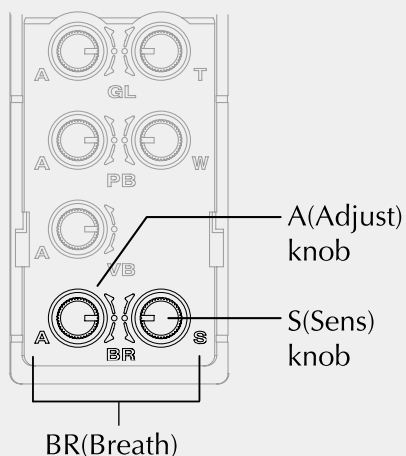

as temperature. In this case, simply adjust the sensors again. Also, if you are just beginning with the EWI4000s, you may want to set the Breath Sensor lightly (by turning the "S" (Sense) knob in the clockwise direction) for easy blowing. But with practice, you can adjust the Breath Sensor to heavy for a more expressive performance.

That's all there is to adjusting the EWI4000s' various settings.

Now try to play the EWI4000s and experiment with its features. The EWI is a musical instrument much like other acoustic instruments, so the more you practice, the better you will play. At first, you may find playing the EWI challenging, but we believe you will find the EWI to be a fantastic instrument with unlimited possibilities. There is no hard and fast rules for playing the EWI. We encourage you to find your own playing style.

Chapter 3 Playing EWI4000s with Internal Sound

Selecting the Internal Sounds (Program)

■ Selecting the Internal Sounds (Program)

The EWI4000s has 100 internal preset sounds. Each sound is called a Program and you switch between them by selecting its Program number.

1. While not touching any Note keys, touch the [Program] key with your finger.

The current program number is displayed on the Program/Data display while touching the [Program] key. If

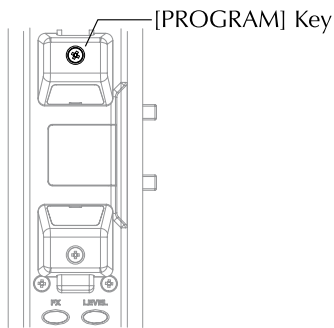

you release your finger from the [Program] key, the Program/Data display returns to its previous state. To switch to a different program, hold in the [Program] key.

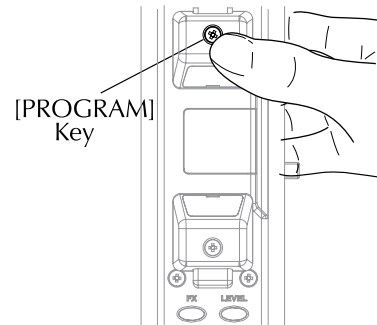

Note: If you touch any Note keys, the Program/Data display shows the program number assigned to that specific note, not the currently selected Program number.

2. While holding in the [Program] key, you can select the Program number you wish to play by pressing the [HOLD] button or the [OCT] button.

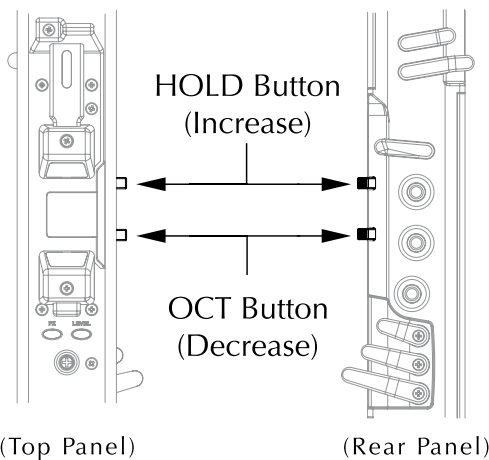

While showing the Program number by touching the [Program] key, the [HOLD] button works as “+” (increasing the Program number) and the [OCT] button works as “-” (decreasing the Program number).

3. The sound will change to match the currently displayed Program number after you release the [Program] key.

■ Assigning a Program number to the key note

You can change the Program number directly by touching the Note keys after assigning a Program number to the Key note. Instead of increasing/ decreasing through the Program numbers by using the [HOLD] or [OCT] button. This feature allows you to access the Program you wish quickly during live performances.

Note: You can only store one program number per Key note, regardless of the fingering or octave.

1. Select the Program number you wish to assign to the Key note as described in “Selecting the internal Sounds (Program)”.
2. While holding in the [Program] key, press the [SETUP] key

The selected Program number will blink on the Program/Data display.

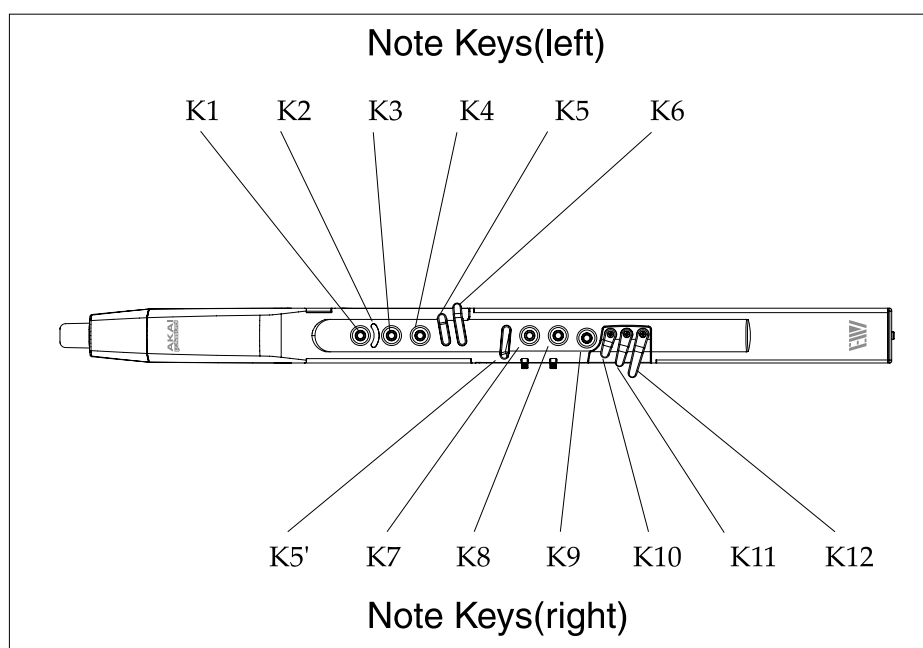
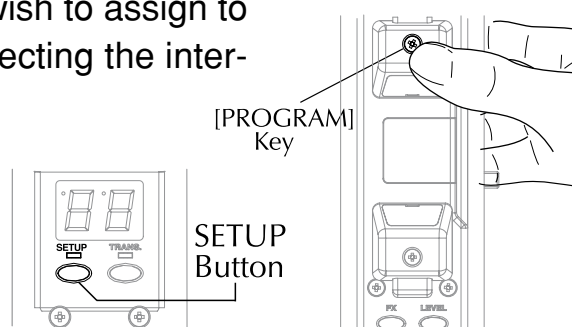

3. Touch the Note key you wish to assign to the selected program.
4. Blow into the Mouthpiece

The selected Program will be assigned to the Key note you touch.

■ Recalling the program number assigned to a key note

This explains how to recall a Program number that is assigned to a Key note.

1. While touching the [Program] key, touch the Note key you wish to recall.

The Program/Data display will show the Program number currently assigned to that Key Note.

2. Blow into the Mouthpiece.

The program number will be changed.

Note: While touching the [Program] key, the sound does not occur when blowing into the Mouthpiece.

Alternate way of Selecting the Program number

Selecting a Program number without touching the [Program] key

Selecting Programs is usually done by touching the [Program] key. But the EWI4000s allows you to change programs by pressing the [HOLD] button or the [OCT] button with the following setting. It may be convenient when you need to change the program number during while playing a song. In this way, the [HOLD] button or [OCT] button works as the Program number Up or the Program number Down, instead of the [HOLD] function or the [OCT] function.

■ Program Up with the [HOLD] button

Note: While this setting is done, you cannot use the [HOLD] function.

1. Press the [SETUP] button.

While pressing the [SETUP] button, “Ad” is shown on the Program/Data display.

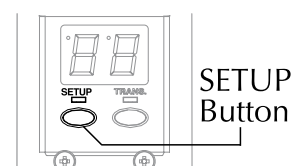

2. While pressing the [SETUP] button, select “Ho” (Hold) by pressing the [HOLD] button.

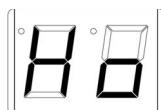

It allows you to select the setup parameter by pressing the [HOLD] or the [OCT] button while pressing the [SETUP] button.

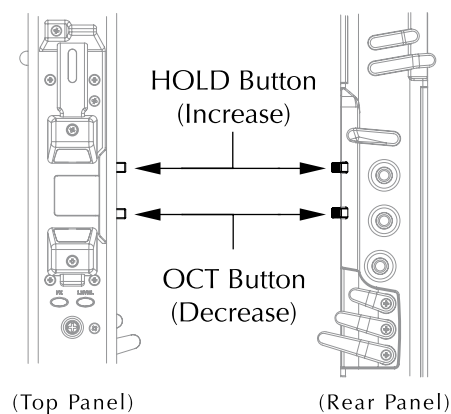

3. After selecting “Ho”, release the [SETUP] button.

4. Select the “UP” by pressing the [HOLD] button or the [OCT] button



While “UP” is selected, the [HOLD] button works as the Program number Up.

5. Press the [SETUP] button.

The EWI4000s returns to the “PLAY” mode.

■ Program Down with the [OCT] button

Note: While this setting is done, you cannot use the Octave function.

1. Press the [SETUP] button.

While pressing the [SETUP] button, “Ad” is shown on the Program/Data display.

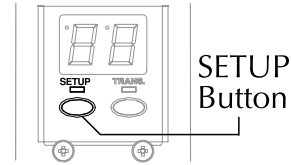

2. While pressing the [SETUP] button, select “Oc” (Octave) by pressing the [OCT] button.



It allows you to select the setup parameter by pressing the [HOLD] or the [OCT] button while pressing the [SETUP] button.

3. After selecting “Oc”, release the [SETUP] button.

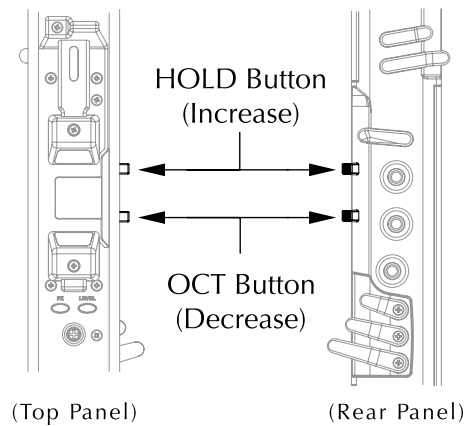

4. Select “dn” (down) by using the [HOLD] button or the [OCT] button

While “dn” is selected, the [OCT] button works as the Program number Down.

5. Press the [SETUP] button.

The EWI4000s returns to “PLAY” mode



With the above setting, you can change the Program number only while using the [HOLD] button or the [OCT] button without touching the [Program] key.

When you press either the [HOLD] or the [OCT] button, the current Program number will be shown on the Program/Data display, and then continuing to press the [HOLD] button will continue the Program number Up, and continuing to press the [OCT] button will continue the Program number Down.

You can set only either the [HOLD] or the [OCT] button as the Program Up or the Program Down. In this case, you can do both Program Up and Down by using both the [HOLD] and the [OCT] button.

When you are using the [HOLD] button as the Program Up and the [OCT] button as the Octave function, while pressing the [HOLD] button, the [OCT] button works as the Program Down. For Example, when selecting the Program number “10”, if you press the [HOLD] button, the Program will be changed to “11”, then if you press the [OCT] button while pressing the [HOLD] button, the Program will be changed to “10”, and if you press the [OCT] button again, the Program will be changed to “9”.

Adjusting the Volumes for Sound / Effect

■ Adjusting the Main Volume

This procedure adjusts the main output volume of the EWI4000s. (01-30)

1. Press the [LEVEL] button

While pressing the [LEVEL] button, the current volume value is shown on the Program/Data display.

2. While continuing to press the [LEVEL] button, adjust the volume by pressing the [HOLD] or the [OCT] button.

The [HOLD] button works as (+), and the [OCT] button works as (-).

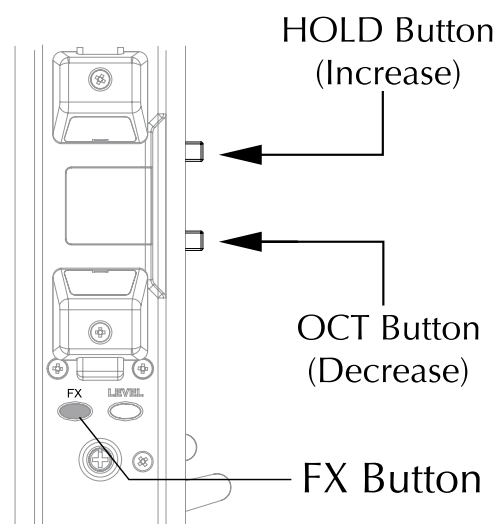

■ Adjusting the volume of each Program

This procedure adjusts the output volume of each Program individually. This affects only the output volume of the selected Program and does not affect the EWI's main output volume. The volume setting of each Program is stored in the EWI4000s.

1. Select the program you wish to adjust the volume.

2. While pressing the [LEVEL] button, press the [SETUP] button.

The current volume value is shown on the Program/Data display.

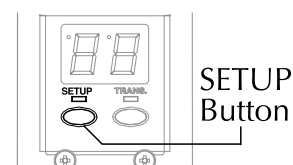

3. Adjust the volume by pressing the [HOLD] button or the [OCT] button.

The [HOLD] button works as (+), and the [OCT] button works as (-).

4. Press the [SETUP] button.

The EWI4000s returns to the "PLAY" mode, and your settings are stored internally.

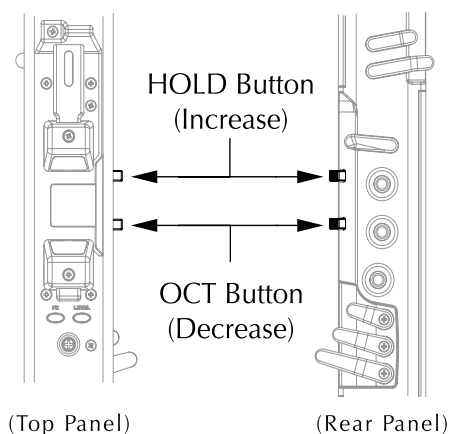

■ Adjusting the Reverb volume

This procedure adjusts the overall Reverb effect volume of the EWI4000s.

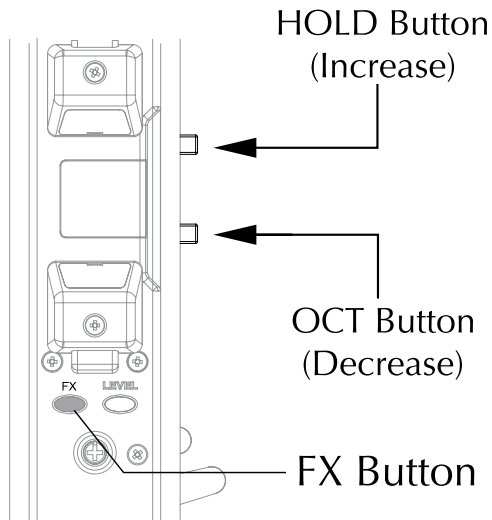

1. Press the [FX] button.

While pressing the [FX] button, the current Reverb effect volume is shown on the Program/Data display.

2. While continuing to press the [FX] button, adjust the volume by pressing the [HOLD] button or the [OCT] button.

The [HOLD] button works as (+), and the [OCT] button works as (-).

■ Adjusting the Reverb effect volume of each program

This procedure adjusts the Reverb effect volume on each Program. It affects only the Reverb effect volume of the selected Program, but does not affect the overall Reverb effect volume. The Reverb effect volume of each program is stored in the EWI4000s.

1. Select the program you wish to adjust the Reverb effect volume.

2. While pressing the [FX] button, press the [SETUP] button.

While pressing both the [FX] button and [SETUP] button, “rb” is shown on the Program/Data display. When you release both buttons, the current Reverb effect volume of the selected program will be shown on the Program/Data display.

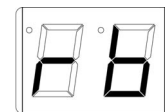
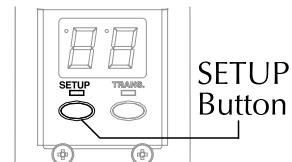

3. Adjust the Reverb effect volume by pressing the [HOLD] button or the [OCT] button.

The [HOLD] button works as (+), and the [OCT] button works as (-).

4. Press the [SETUP] key.

The EWI4000s returns to the “PLAY” mode.

■ Adjusting the Delay effect volume of each program

This procedure adjusts the Delay effect volume of each Program. This will only affect the Delay effect volume of the selected program but does not affect the overall Reverb effect volume. The Delay effect volume setting of each program is stored in the EWI4000s.

1. Select the program you wish to adjust the Delay effect volume.

2. While pressing the [FX] button, press the [SETUP] button.

While pressing both the [FX] button and [SETUP] button, “rb” is shown on the Program/Data display.

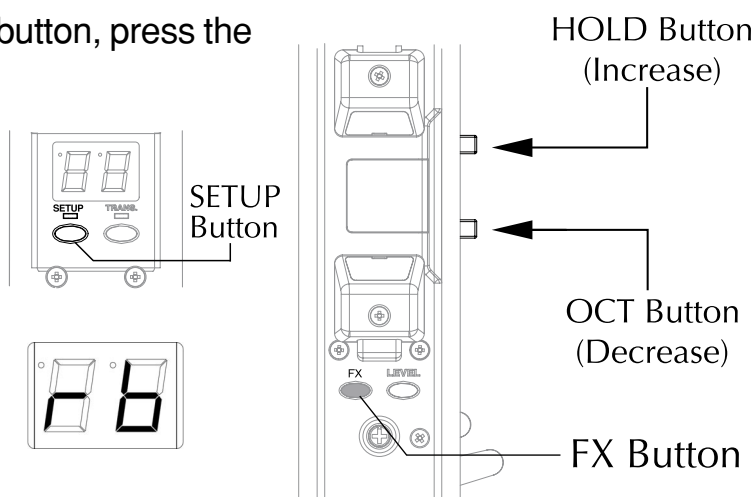

3. While pressing the [SETUP] button, release the [FX] button, and then press the [HOLD] button so that the Program/Data display now shows “dL” .

When you release both the [SETUP] button and the [HOLD] button while “dL” is shown, the current Delay volume of the selected program will be shown on the Program/Data display.



4. Adjust the Delay volume by pressing the [HOLD] button or the [OCT] button.

The [HOLD] button works as (+), and the [OCT] button works as (-).

5. Press the [SETUP] key.

The EWI4000s returns to the “PLAY” mode

■ Adjusting the Chorus effect On/Off on each program

This procedure selects whether the Chorus effect is set to On or Off for each program. The Chorus effect setting of each program is stored in the EWI4000s.

1. While pressing the [FX] button, press the [SETUP] button.

While pressing both the [FX] button and [SETUP] button, “rb” is shown on the Program/Data display.

2. While pressing the [SETUP] button, release the [FX] button, and then press the [HOLD] button so that the Program/Data display shows “CH” .

When you release both the [SETUP] button and the [HOLD] button while “CH” is shown, the current Chorus setting of the selected program will be shown on the Program/Data display.

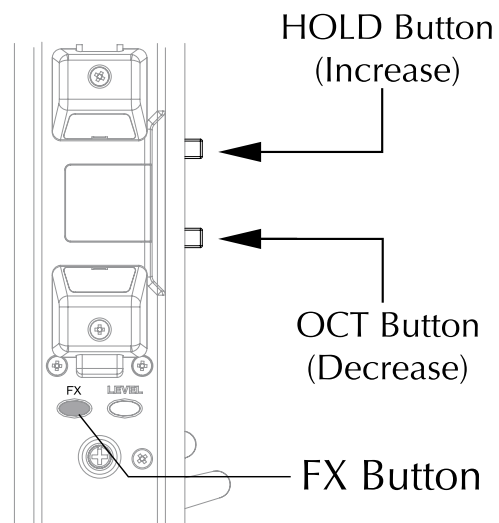
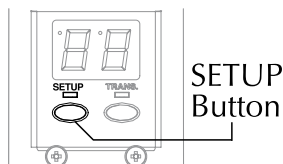

3. Select the Chorus to either “on” or “OF” by pressing the [HOLD] button or the [OCT] button.

If you select “on”, the chorus effect is active on the selected program.

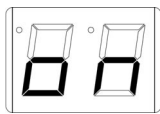

4. Press the [SETUP] key.

The EWI4000s returns to the “PLAY” mode.

Octave Function (OCT button)

By setting the [OCT] button to the Octave function and pressing the [OCT] button, you can use the Octave function to add a note one octave lower that you are currently playing.

■ Setting the Octave function to OCT button

1. Press the [SETUP] button.

While pressing the [SETUP] button, “Ad” is shown on the program/Data display.

2. While pressing the [SETUP] button, select “Oc” (Octave) by pressing the [HOLD] button.

It allows you to select the setup parameter by pressing the [HOLD] or the [OCT] button while pressing the [SETUP] button.

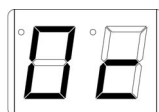

3. After selecting “Oc”, release the [SETUP] button.

The Program/Data display shows “OF”. This means that the Octave function is set to OFF (not active).



4. Select the “on” (ON) by pressing the [HOLD] button or the [OCT] button.

If “on” is selected, the Octave function is set to ON (Active)

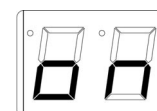

5. Press the [SETUP] button.

The EWI4000s returns to the “PLAY” mode.

Now the [OCT] button is set to the Octave function.

6. Press the [OCT] button.

The Octave function is ON when the OCT LED is lit. Press the [OCT] button again, and then the Octave function is Off with the OCT LED off.

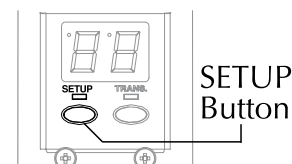
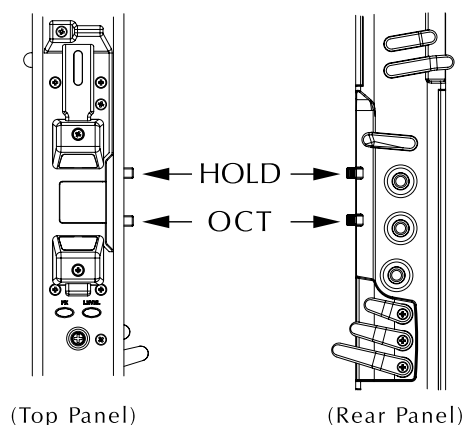

Hold function (HOLD button)

If you activate the HOLD button by pressing it, the EWI4000s will enter HOLD mode. HOLD mode allows you to play and hold a note and then play a line over the held note. The note will hold as long as you are playing a legato phrase.

For example, while you are playing a legato passage in Hold mode, the EWI4000s will sustain the first note you play and then allow you to play a melody over it as long as you are playing a phrase. When you end the phrase or re-articulate a new note, the EWI4000s will end the held note and the new note will be held note.

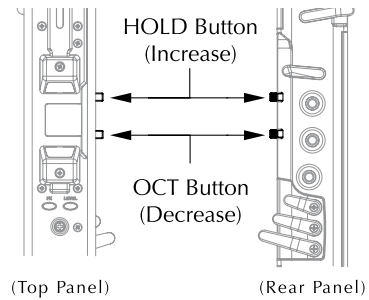

Note: If the Hold function is assigned to the HOLD button, the overall output level will be decreased to eliminate distortion.

Setting the HOLD function to HOLD button

1. Press the [SETUP] button.

While pressing the [SETUP] button, “Ad” is shown on the program/Data display.

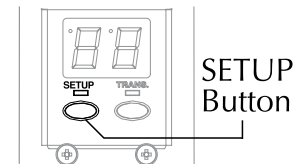

2. While pressing the [SETUP] button, select “Ho” (Hold) by pressing the [HOLD] button.

It allows you to select the setup parameter by pressing the [HOLD] button or the [OCT] button while pressing the [SETUP] button.

3. After selecting “Ho”, release the [SETUP] button.

“OF” is shown on the Program/Data display. This means that the Hold function is set to OFF (not active).

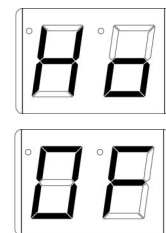

4. Select “So” (Sostenuto) by pressing the [HOLD] button or the [OCT] button.

While “So” or “Su (Sustain) is selected, the Octave function is active.

There are two additional settings available: “Su” and “So”. The difference between the “Su” and “So” are

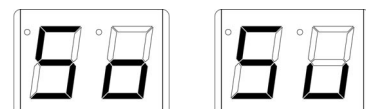

when the EWI4000s is being used as a MIDI controller (transmitting the MIDI signal). See using the EWI4000s as a MIDI controller for more information.

5. Press the [SETUP] button.

The EWI4000s returns to the “PLAY” mode.

Now the [HOLD] button is set to the HOLD function

6. Press the [HOLD] button.

The HOLD function is ON when the HOLD LED is lit. Press the [HOLD] button again, and then the HOLD function is Off with the HOLD LED off.

Selecting “Time” or “Rate” on the Glide effect

It allows you to select either “Time” or “Rate” for the pitch shift effect of the Glide effect.

Rate: The speed of the pitch shift is constant, regardless the pitch shift range of the Glide effect. For example, if the pitch shift range is narrow, it shifts the pitch for a short time. If the pitch shift range is wide, it shifts the pitch for a long time.

Time: The time of the pitch shift is constant, regardless the pitch shift range of the Glide effect. For example, if the pitch shift range is narrow, it shifts the pitch slowly. If the pitch shift range is wide, it shifts the pitch quickly.

1. Press the [SETUP] button.

While pressing the [SETUP] button, “Ad” is shown on the program/Data display.

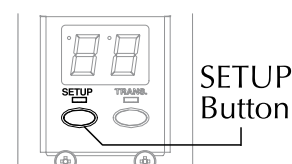

2. While pressing the [SETUP] button, select “GL” (Glide) by pressing the [HOLD] button.



It allows you to select the setup parameter by pressing the [HOLD] or the [OCT] button while pressing the [SETUP] button.

3. After selecting “GL”, release the [SETUP] button.
4. Select either “r” (Rate) or “t” (Time) by pressing the [HOLD] button or the [OCT] button.

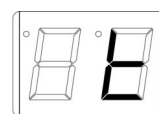
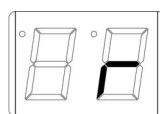

5. Press the [SETUP] button.

The EWI4000s returns to the “PLAY” mode.

Adjusting the Key Delay

The Key Delay function adjusts the response to the Key Touch, when you have unexpected sounds while playing the EWI4000s. The key touch response of the EWI4000s is preset for rather quick fingering. As a result, you may produce unexpected sounds caused by complex fingering. In this case, you will find that you can play more smoothly by setting the Key Touch response with the Key Delay function.

1. Press the [SETUP] button.

While pressing the [SETUP] button, “Ad” is shown on the program/Data display.

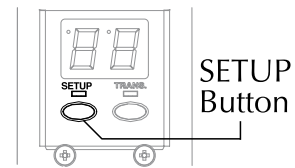

2. While pressing the [SETUP] button, select “dL” (Key Delay) by pressing the [HOLD] button.

It allows you to select the setup parameter by pressing the [HOLD] or the [OCT] button while pressing the [SETUP] button.

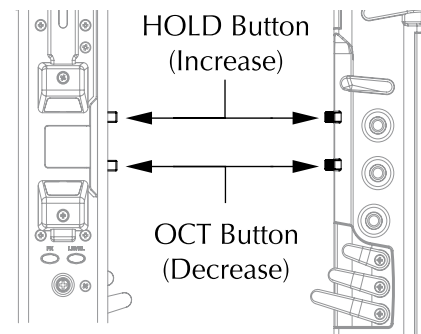

3. After selecting “dL”, release the [SETUP] button.

(Top Panel)

(Rear Pane)

The currently selected Key delay value will be displayed on the Program/Data display.

4. Adjust to the desired value by pressing the [HOLD] button or the [OCT] button.

As you set a large value, the sounding response will be slow accordingly.

The [HOLD] button works as (+), and the [OCT] button works as (-).

Note: You can smoothly play notes with a large key delay value. However, it may prevent you from playing a speedy phrase. Set a value as small as needed.

5. Press the [SETUP] button.

The EWI4000s returns to the “PLAY” mode.

Note: If you press any button except the [SETUP], [HOLD], and [OCT] button, your setting value is ignored and will return back to the original value.

Transpose function

The Transpose function allows you to play the EWI4000s in a transposed key. If you use the Transpose function, the standard “C” position is transposed to the note you have defined.

When you press the [TRANS] button, the Transpose function switches “ON”. When you press the [TRANS] button again, it switches “Off”.

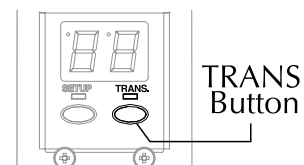

■ Setting the Transpose function

While pressing the [TRANS] button, the current Transpose note is shown on the Program/Data display. At this time, you can set the Transpose note by pressing the [HOLD] button or the [OCT] button.

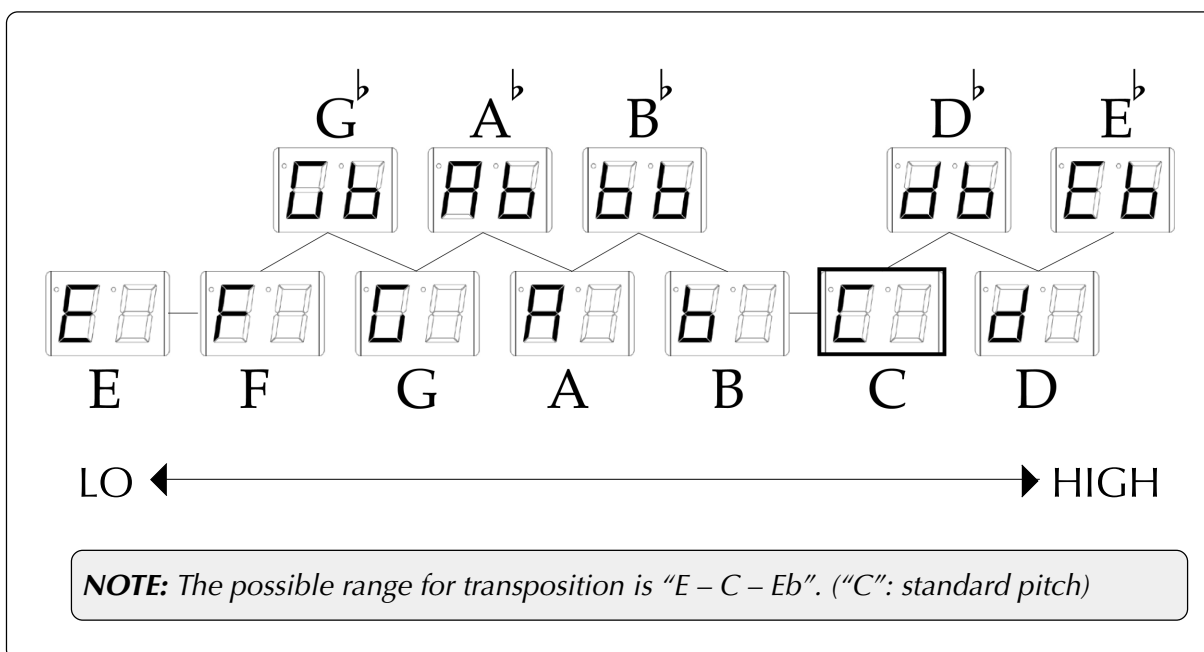

Tuning

This sets the tuning of the EWI4000s. It is used when you play with other musicians/instruments.

1. Press the [SETUP] button.

While pressing the [SETUP] button, “Ad” is shown on the program/Data display.

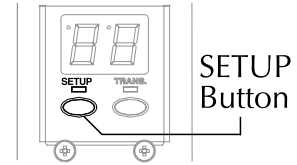

2. While pressing the [SETUP] button, select “tu” (Tuning) by pressing the [HOLD] button.

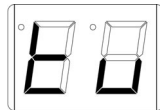

It allows you to select the setup parameter by pressing the [HOLD] or the [OCT] button while pressing the [SETUP] button.

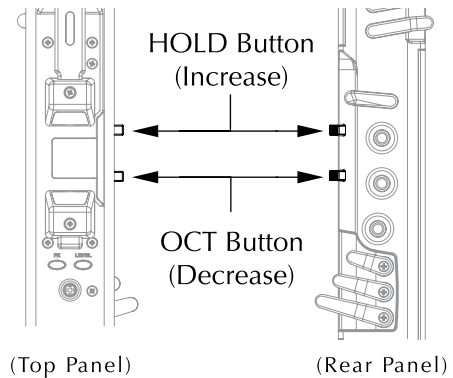

3. After selecting “tu”, release the [SETUP] button.

The “40” is shown on the Program/Data display. This means that the basic A note is set to 440Hz.



4. Adjust the proper value by pressing the [HOLD] button or the [OCT] button

The [HOLD] button works as (+), and the [OCT] button works as (-).

The setting range is between 416Hz and 465Hz.

5. Press the [SETUP] button.

The EWI4000s returns to the “PLAY” mode.

Note: If you press any button except the [SETUP], [HOLD], and [OCT] button, your tune setting is ignored and The EWI4000s returns to the original tuning value.

Editing the internal sound by using the computer

Parameters within the internal sound /Effect cannot be edited/adjusted by the EWI4000s itself. You can edit/adjust them by connecting to your computer and using the Sound Editor software for the EWI4000s. The edited sound/effect will be stored in the EWI4000s. MIDI cables are used for the communication between the EWI4000s and the computer.

The Sound Editor for the EWI4000s can be downloaded from our web site.

Refer to our web site (<http://www.akaipro.com>) for the details on the EWI4000s Sound Editor.

Chapter 4 : Using the EWI4000s as a MIDI controller

As the EWI4000s has Internal sounds and effects, you can play it immediately by itself. You can also use the EWI4000s as MIDI controller for an external MIDI sound module/synth.

■ About MIDI

MIDI is a standard for transferring the performance data between electronic instruments regardless of the manufacturer. Devices are connected using a special cable called a MIDI cable. For example, when you connect the EWI4000s' MIDI OUT to MIDI IN of the MIDI sound module, the performance data you made with your EWI4000s will be sent to the MIDI sound module, which plays the sound. MIDI can transfer only the performance data, not the actual sound. To transfer as much data as possible through one MIDI cable, there are 16 MIDI channels. The MIDI channel is very important when you handle MIDI. You must set the same MIDI channels for the both the EWI4000s and the sound module even if you play the sound from the EWI4000s. For example, if the EWI4000s 'output channel is set to 1, the sound module's input channel should also be 1.

The EWI4000s transmits not only Note Number with the Velocity but also some Control Changes such as Breath Controller, Portamento, Sustain, etc.

■ To use the EWI4000s as a MIDI controller, you will need the following

MIDI cable

MIDI sound module or MIDI sequencer

■ Connection

Connect the MIDI cable between the MIDI OUT of the EWI4000s and the MIDI IN of the external MIDI sound module.

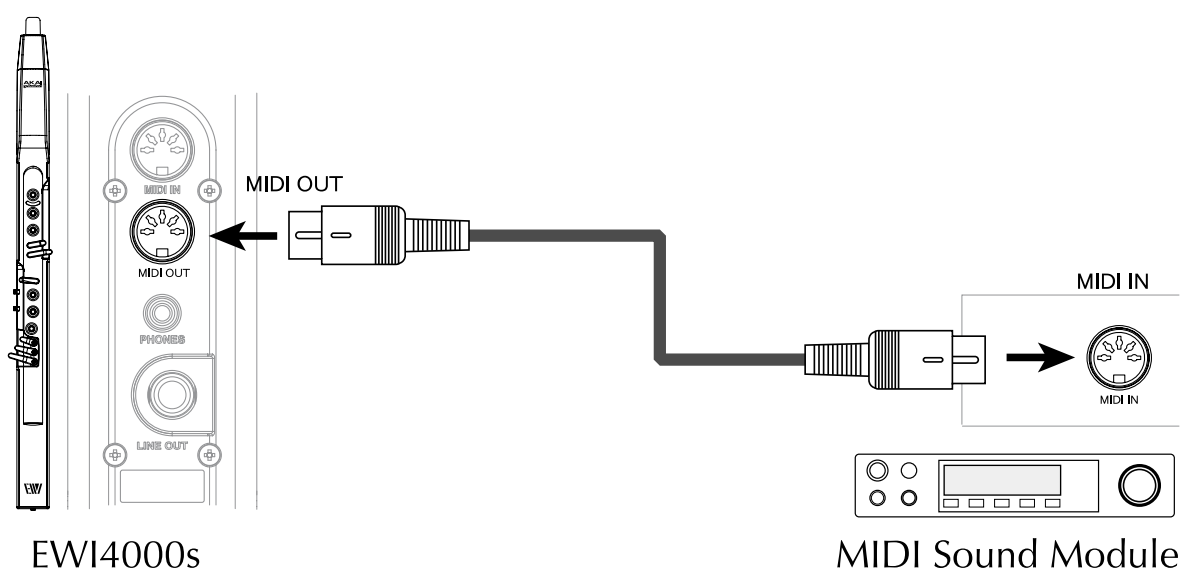

■ Setting of the external MIDI sound module

1. Set the external sound model so that it responds to the incoming MIDI signal.
2. Set the received MIDI channel to “1”.
3. Select the sound library you wish to play.

Note: Refer to the operator’s manual of your external MIDI sound module/synth for details.

■ Setting of the EWI4000s

The EWI4000s is set so that it transfers the MIDI signal with its initial setting. You can control an external MIDI sound module only by connecting a MIDI cable to it.

Transmitted Information from the EWI4000s MIDI OUT

- Breath strength (and weakness) is converted to MIDI Control Change No. 07 (Volume). If the external sound module responds to MIDI volume message, you can control the output volume of the sound module with your breath strength. Depending on the sound module, your breath strength can change not only the output volume but also the sound character. For example, if you set the cut-off frequency of the sound module with MIDI Control Change No. 7 (Volume), your breath strength can change the sound character by changing the cut-off frequency of the sound. Refer to the operator's manual of the sound module for proper set up.
- The Bend Plate information is converted to MIDI Pitch Bend information. If the external sound module responds to this information (Pitch Bend is a Registered Parameter), you can control Pitch Bend of the sound module with the Bend Plate of the EWI4000s. Also, the vibrato information is converted to MIDI Pitch Bend information. If the external sound module accepts it, you can play vibrato on the sound module.
- The Glide information is converted to MIDI Control Change No. 65 (Portamento) and No. 05 (Portamento Time). If the external sound module accepts them, you can control the sound module's Portamento with the Glide of the EWI4000s.

■ Program Change

You can change the sound program of an external sound module by using MIDI Program Change information from the EWI4000s. The operation of Program Change is the same as "Selecting the internal Sounds (Program)" on page 20. When the Program of the EWI4000s is changed, the MIDI Program Change of the same number is transmitted.

Using the EWI4000s as a MIDI controller (Application)

■ Changing the MIDI Channel

This sets the MIDI OUT channel of the EWI4000s.

1. Press the [SETUP] button.

While pressing the [SETUP] button, “Ad” is shown on the program/Data display.

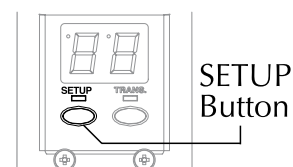

2. While continuing to press the [SETUP] button, select “CH” (Channel) by pressing the [HOLD] button.

It allows you to select the setup parameter by pressing the [HOLD] button or the [OCT] button while pressing the [SETUP] button.

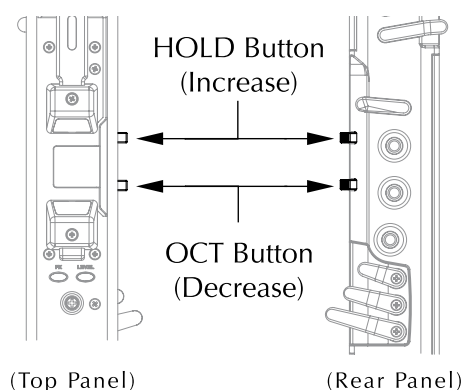

3. After selecting “CH”, release the [SETUP] button.

The current MIDI Channel No. is shown on the Program/Data display.

4. Select the MIDI Channel No. you wish by pressing the [HOLD] button or the [OCT] button.

The [HOLD] button works as (+), and the [OCT] button works as (-).

5. Press the [SETUP] button.

The EWI4000s returns to the “PLAY” mode.

Note: If you press any button except the [SETUP], [HOLD], and [OCT] button, your setting MIDI Channel is ignored and it returns to the original number.

■ Changing the Breath Sensor output

It allows you to change the Breath Sensor output to transmit some MIDI Control Change information. You can select several MIDI Control Changes at the same time.

1. Press the [SETUP] button.

While pressing the [SETUP] button, “Ad” is shown on the program/Data display.

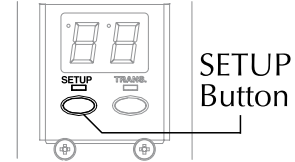

2. While pressing the [SETUP] button, select “bS” (Breath Sensor) by pressing the [HOLD] button.

It allows you to select the setup parameter by pressing the [HOLD] or the [OCT] button while pressing the [SETUP] button.

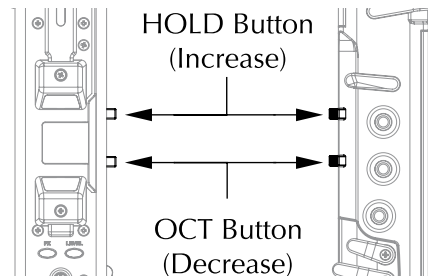
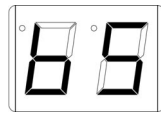

3. After selecting “bS”, release the [SETUP] button.

The currently selected Breath Sensor setting will be shown on the Program/Data display. The selectable MIDI events in this field are as follows:

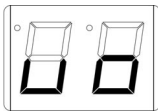

“vo” : Volume (07)



“EP” : Expression (11)



“AF” : Aftertouch



“br” : Breath control (02)

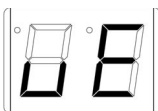

“vE” : Velocity data

4. Select the MIDI event you wish by using the [HOLD] button or the [OCT] button, and then press the [TRANS] button.

By pressing the [TRANS] button, you can select whether its MIDI event will be transmitted or not. If you choose to transmit the MIDI event, the “dot” LED in the Program/Data display will light up.

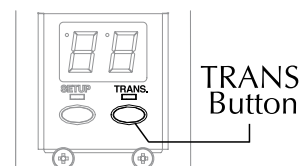

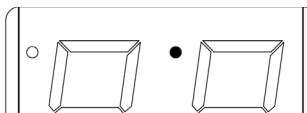

The LED “dot” will need to be lit to transmit its MIDI event..

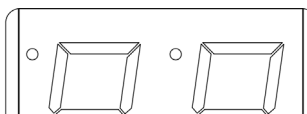

If the LED “dot” is not lit, the EWI4000s will not transmit its MIDI event.

You can select several MIDI events to transmit at the same time.

If you select “vE”, you can transmit the MIDI Velocity data by your breath strength.

5. Press the [SETUP] button.

The EWI4000s returns to the “PLAY” mode.

Note: If you press any button other than the [SETUP], [TRANS], [HOLD], or [OCT] button, your setting MIDI event is ignored and it returns to the original setting.

■ Setting the MIDI Velocity value

In the case that the “vE” is selected on the setting of the Breath Sensor output, the EWI4000s transmits the MIDI Velocity being changed by your breath strength. If the “VE” is not selected on the setting of the

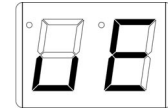

Breath Sensor output, the EWI4000s transmits a fixed MIDI Velocity value. You can set a fixed MIDI Velocity as follows.

1. Press the [SETUP] button.

While pressing the [SETUP] button, “Ad” is shown on the Program/Data display.

2. While continuing to press the [SETUP] button, select “vE” (Velocity) by pressing the [HOLD] button.

It allows you to select the setup parameter by pressing the [HOLD] button or the [OCT] button while pressing the [SETUP] button.

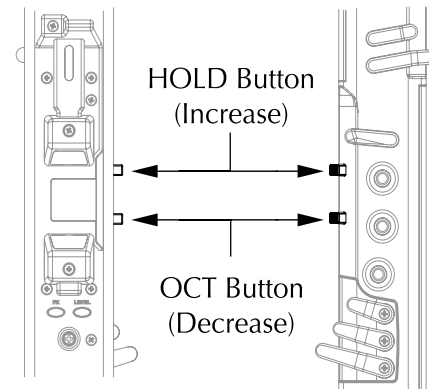
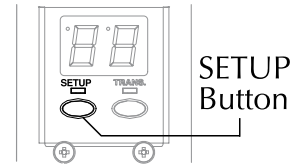

(Top Panel)

(Rear Panel)

3. After selecting “vE”, release the [SETUP] button.



The current MIDI Velocity value will be shown on the Program/Data display. The range of the selectable MIDI velocity is between 1 and 127, and the value of only the lower two digits are shown on the display. A lit LED “dot” on the display means a value over 100, for example, a “20” and a lit LED “dot” on the display means “120”.

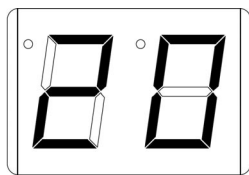

“20” and “no lit LED dot”



“20” and “a lit LED dot”

4. Select the fixed MIDI velocity you wish by pressing the [HOLD] button or the [OCT] button, and then press the [TRANS] button.

4. Press the [SETUP] button.

The EWI4000s returns to the “PLAY” mode.

■ Changing the Vibrato Sensor output to another MIDI event

As the Vibrato sensor information is mixed with the Pitch Bend information, you can get a Vibrato effect of changing the pitch by biting the Vibrato sensor. By mixing the Vibrato sensor information with the Breath sensor information, you can get the Vibrato effect of changing the volume and/or sound character.

1. Press the [SETUP] button.

While pressing the [SETUP] button, “Ad” is shown on the Program/Data display.

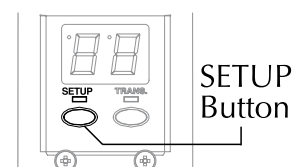

2. While pressing the [SETUP] button, select “vS” (Vibrato Sensor) by pressing the [HOLD] button.

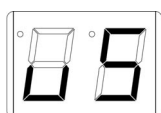

It allows you to select the setup parameter by pressing the [HOLD] button or the [OCT] button while pressing the [SETUP] button.

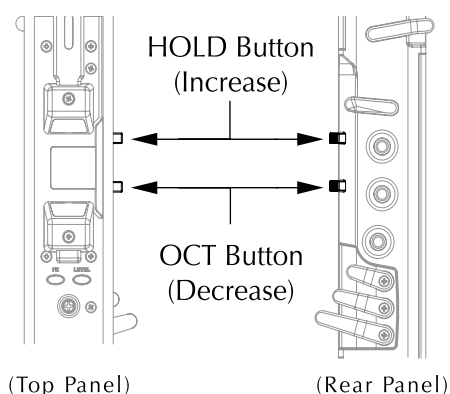

3. After selecting “vS”, release the [SETUP] button.

“Pb” is shown on the Program/Data display.



“Pb” will mix the Vibrato sensor information to the Pitch Bend information.

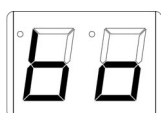

“bo” will mix the vibrato sensor information to the Breath Sensor information.

4. Select the “Pb” or “bo” by pressing the [HOLD] button or the [OCT] button, and then press the [TRANS] button.

By pressing the [TRANS] button, you can select whether the MIDI event will be transmitted or not. If you select to transmit the MIDI event, the LED “dot” on the Program/Data display will light up.

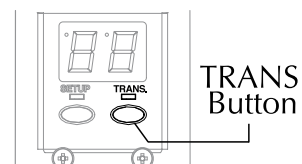

5. Press the [SETUP] button.

The EWI4000s returns to the “PLAY” mode.

Note: If you press any button except the [SETUP], [TRANS], [HOLD], and [OCT] button, your setting MIDI event is ignored and it returns to the original setting.

■ Octave function (OCT button) on MIDI Transmit

The Octave function is also available while the EWI4000s is used as MIDI controller. While the Octave function is On, the EWI4000s transmits a note one octave lower than the original note, as well as the actual note being played.

To use the Octave function on MIDI Transmit, you should set the OCT button to the Octave function. This setting is same as the “Setting the Octave function to OCT button” in “Chapter 3: Playing EWI4000s with Internal Sound” on page 29. Please refer to it.

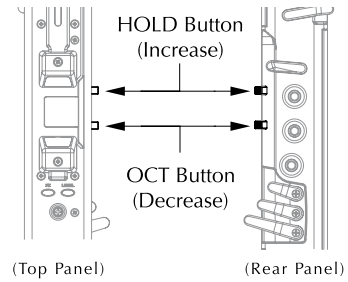

■ Hold function (HOLD button) on MIDI Transmit

The Hold function is also available while the EWI4000s is used as a MIDI controller. The Hold function on MIDI Transmit is a little different than using the internal sound module. The Hold function is transmitted via MIDI in the following two ways, allowing you to make your selection in the Setup mode.



So: Transmits a MIDI Control Change No. 66. (Sostenuto). When you play the EWI4000s with Legato, the MIDI Control Change No.66 (Sostenuto) will be transmitted just after the first note. Only the first note will be held - later notes won't be held. When you stop blowing, the Sostenuto will cease.

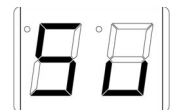

Su: Transmits a MIDI Control Change No. 64 (Sustain). When you play the EWI4000s with Legato, all notes will be held. When you stop blowing, the Sustain will cease.

■ Setting the Hold function

This procedure selects either MIDI Control Change No. 66. (Sostenuto) or the MIDI Control Change No. 64 (Sustain), when you use the HOLD function while transmitting MIDI from the EWI4000s.

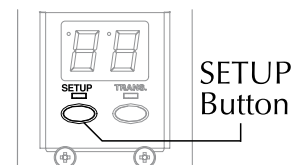

1. Press the [SETUP] button.

While pressing the [SETUP] button, “Ad” is shown on the program/Data display.

2. While continuing to press the [SETUP] button, select “Ho” (Hold) by pressing the [HOLD] button.



3. After selecting the “Ho”, release the [SETUP] button.

The current setting is shown on the Program/Data display.

4. Select “So” or “Su” by pressing the [HOLD] button or the [OCT] button.

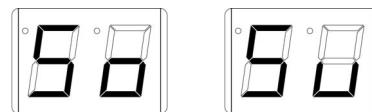

If “OF” is selected, the Hold function is OFF.

5. Press the [SETUP] button.

The EWI4000s returns to the “PLAY” mode



■ Selecting Portamento ON/OFF while touching the Glide plate

The EWI4000s converts the Glide information to MIDI Control Change No. 65 (Portamento) and No. 05 (Portamento Time) when touching the Glide plate. However, some sound modules may change the sound by receiving the Portamento event. In this case, it allows you to select the Portamento to Off, which does not transmit the Portamento event even touching the Glide plate.

1. Press the [SETUP] button.

While pressing the [SETUP] button, “Ad” is shown on the program/Data display.

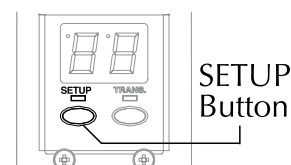

2. While pressing the [SETUP] button, select “Po” (Portamento) by pressing the [HOLD] button.

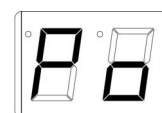

It allows you to select the setup parameter by pressing the [HOLD] button or the [OCT] button while pressing the [SETUP] button.

3. After selecting “Po”, release the [SETUP] button.

The “on” is shown on the Program/Data display.

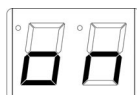

“on” : Transmits a MIDI Control Change No. 65 (Portamento).



“Of” : Does not transmit a MIDI Control Change No. 65 (Portamento) .

4. Select the “on” or “Of” by pressing the [HOLD] button or the [OCT] button.
5. Press the [SETUP] button.

The EWI4000s returns to the “PLAY” mode.

Note: If you press any button except the [SETUP], [TRANS], [HOLD], and [OCT] button, your setting MIDI event is ignored and it returns to the original setting.

Initialize to Factory Preset

By turning the EWI4000s on while holding the [LEVEL], [FX], [SETUP], and [TRANS] buttons, the EWI4000s is reset to the Factory Preset setting.

The following global settings are stored in EWI4000s.

dL : Key delay:02
 CH: Midi channel:01
 tu : Tune:40
 bS : Breath sensor:Only expression is set.
 vS : Vibrato sensor:Only expression is set.
 vE : Velocity:120
 Po : Portamento:on
 Oc : Octave key:OF
 Ho : Hold key:OF
 GL: Glide:r

 Level master:30
 Level preset:30

 Reverb master:21
 - Effect preset -
 CH: Chorus:OF
 dL : Delay:OF
 rb : Reverb:21

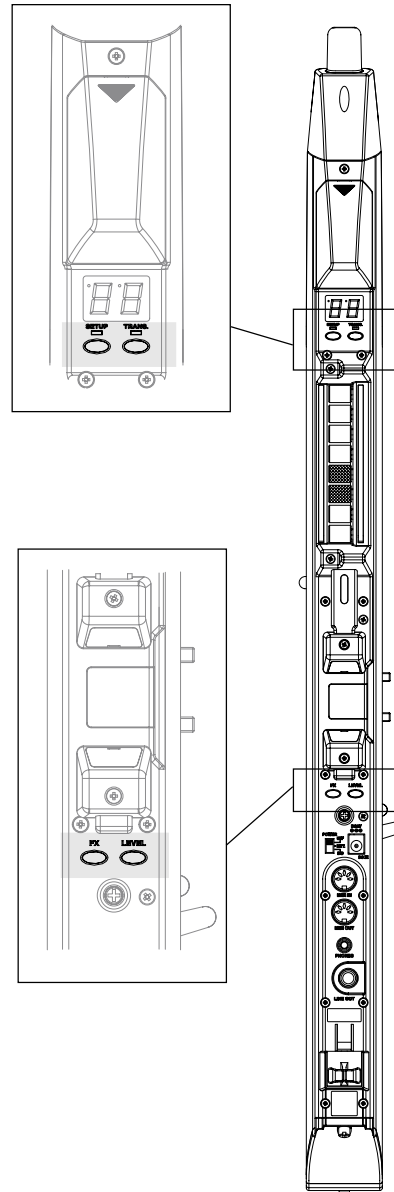

Specifications

■ **EWI4000s Specifications**

Type	Wind-instrument type controller with sound module
Fingering	Saxophone fingering and EWI fingering
Sensors	Note Keys: touch sensors Mouthpiece Breath: air pressure level sensor Lip: pressure level sensor Bend Up/Down Plates: touch sensors Glide Plate: touch sensor Octave Shift Rollers: touch sensors
Program key	touch sensor
Keys	"LEVEL key, FX key, SETUP key, TRANSPOSE key OCT key, HOLD key"
Sensor Adjustment	"Breath Sense, Breath Adjustment, Bend Width, Bend Adjustment," "Glide Time, Glide Adjustment, Vibrato Adjustment"
Terminals	LINE OUT x 1 (1/4 inch Phone Jack) "Headphones OUT x 1 (Dual Mono, Stereo Mini Jack,)" (The recommended minimum headphone impedance is 32 ohms) "MIDI IN x 1, MIDI OUT x 1 (5-pin DIN)" DC IN x 1 (for optional AC adaptor MP-9II)
Other	Removal Cable Clutch
Power requirement	AA (ALKALINE or Rechargeable) battery x 4 (Approx. 8 hours continuous use by batteries except using Headphones) or 9VDC/200mA AC-adaptor MP-9II (Optional)
Dimensions	670.5mm(L) x 61mm(W) x 69mm(D)
Weight	874g (not included Batteries)
Accessories	"Operator's Manual, Neck strap, AA battery x 4, Cleaning Cloth, Mouthpiece Cover"

■ **Sound module**

Sound type	Analog Modeling Synthesizer
Voices	2 (only while Octave & Hold function)
Control range	8 octaves
Sound Source	"2 x Oscillator, 2 x Filters" "Waveforms: Saw Tooth, Triangle, Pulse " "Noise Generator, Formant filter"
Effect	"Reverb, Delay, Chorus"
Sound Capacity	100 (50 preset sound x 2)
Display	7-segment LED x 2
Function	"Transpose, Tune, Note Hold, Octave, Program Change, Key Delay"
Other	Sound Editor software for EWI4000s is available from our Web site

Above specifications and appearance are subject to change without notice.

EWI4000s Standard Fingering Charts

■ Note Keys

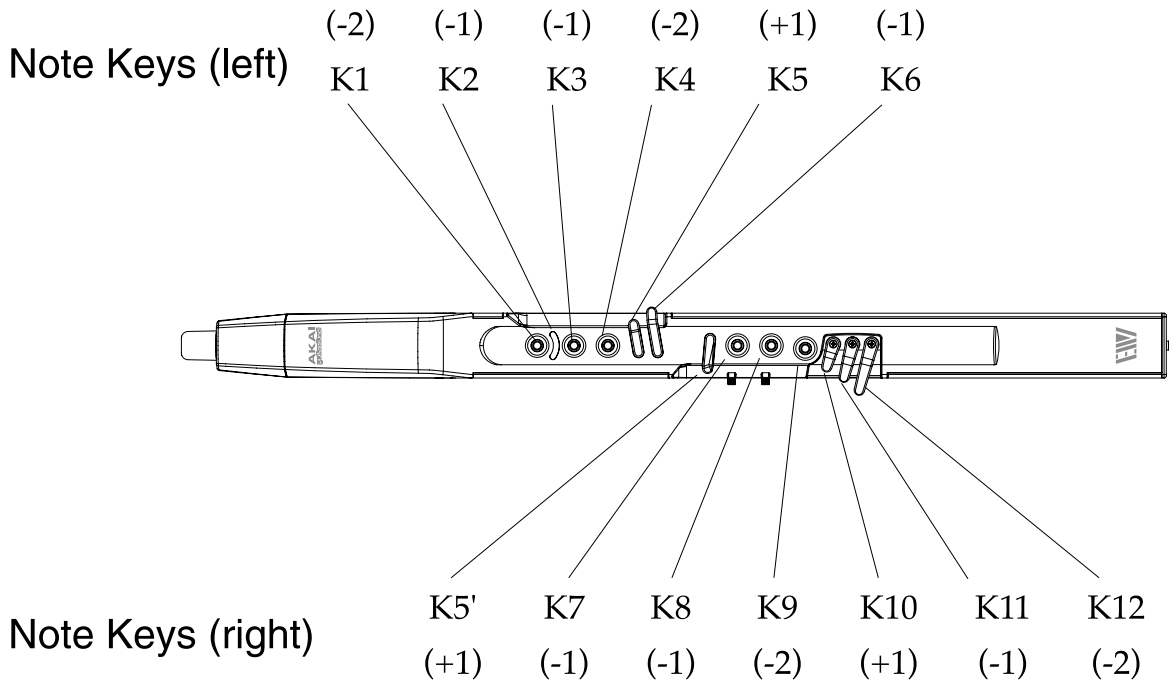

■ Octave Shift Rollers

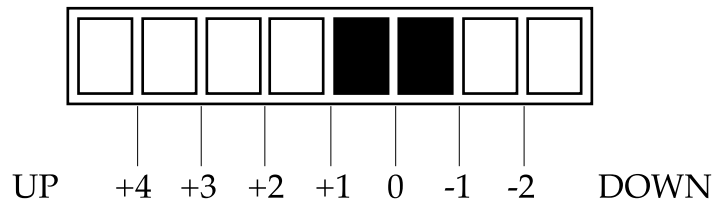

The “0” position produces the standard pitch.











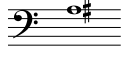





The EWI4000s transmits MIDI note number information from its MIDI OUT terminal within the following ranges (in the table), by the Note Key operation and touch position with Octave Shift Rollers on the EWI4000s.

If you do the Note Key operation on the EWI4000s, you can play other MIDI compatible instruments from the lowest note(A#: 22) to highest (D#: 111), through the EWI4000s.

Touch position on Octave Shift Rollers	Output Range of MIDI note numbers
-2	24 - 36
-1	36 - 48
0	48 - 60
+1	60 - 72
+2	72 - 84
+3	86 - 96
+4	96 - 108

Note: MIDI note number #60 is Middle “C”.







Touch the keys filled in.



NOTE	NOTE KEYS (LEFT)						NOTE KEYS (RIGHT)						OCTAVE SHIFT ROLLERS
	K1	K2	K3	K4	K5	K6	K5'	K7	K8	K9	K10	K11	
 A#	●	☺	●	●	○	▬	○	●	●	●	○	▬	▬
 B	●	☺	●	●	○	▬	○	●	●	●	○	○	▬
 C	●	☺	●	●	○	○	○	●	●	●	○	○	▬
 C#	●	☺	●	●	▬	○	○	●	●	●	○	○	▬
 D	●	☺	●	●	○	○	○	●	●	●	○	○	○
 D#	●	☺	●	●	○	○	○	●	●	●	▬	○	○
 E	●	☺	●	●	○	○	○	●	●	○	○	○	○
 F	●	☺	●	●	○	○	○	●	○	○	○	○	○
 F#	●	☺	●	●	○	○	○	○	●	○	○	○	○
 G	●	☺	●	●	○	○	○	○	○	○	○	○	○
 G#	●	☺	●	●	○	○	▬	○	○	○	○	○	○
 A	●	☺	●	○	○	○	○	○	○	○	○	○	○
 A#	●	☺	●	○	○	○	▬	○	○	○	○	○	○
 B	●	☺	○	○	○	○	○	○	○	○	○	○	○
 C	○	☺	●	○	○	○	○	○	○	○	○	○	○
 C#	○	☺	○	○	○	○	○	○	○	○	○	○	○
 D	○	☺	○	○	▬	○	○	○	○	○	○	○	○

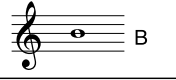
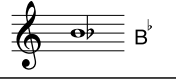

UP +1 DOWN

Substitute Fingerings

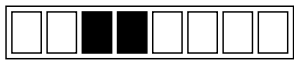
NOTE	NOTE KEYS (LEFT)						NOTE KEYS (RIGHT)						OCTAVE SHIFT ROLLERS
	K1	K2	K3	K4	K5	K6	K5'	K7	K8	K9	K10	K11	
 C#	●	☺	●	●	☺	☺	☺	●	●	●	☺	☺	☺
 C	●	☺	●	●	☺	☺	☺	●	●	●	☺	☺	☺
 B	●	☺	●	●	☺	☺	☺	●	●	●	☺	☺	☺
 B ^b	●	☺	●	●	☺	☺	☺	●	●	●	☺	☺	☺
 B ^b	●	☺	○	○	☺	☺	☺	○	○	○	☺	☺	☺
 C	○	☺	●	○	☺	☺	☺	○	○	○	☺	☺	☺
 C#	○	☺	○	○	☺	☺	☺	○	○	○	☺	☺	☺

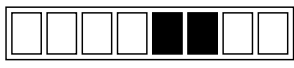
OCTAVE SHIFT ROLLERS
 UP +2 DOWN
 UP +1 DOWN
 UP 0 DOWN

These are only a few example. Refer to a manual for the saxophone, etc., for other possible fingerings.

AKAI professional M.I. Corp.
Model : EW14000s

Date : October, 2005
Version : 1.0

MIDI Implementation Chart

Function	***	Transmitted	Recognized	Remarks
Basic Channel	Default	1 - 16	1 - 16	Memorized
	Changed	1 - 16	1 - 16	
Mode	Default	3	3	2 notes polyphony
	Messages	X	O (All note off)	
	Altered	*****	*****	
Note Number		22 - 111	22 - 111	
	True Voice	(-8 ~ +3 transposed) (*1)	12 - 127	
Velocity	Note on	O: 9n, v=1 - 127 (*2)	O: 9n, v=1 - 127	
	Note off	O: 8n, v=64	O: 8n or 9n, v=0	
After Touch	Key's	X	X	
	Ch's	O	O	
Pitch Bender		O	O	
Control Change	2	O	O	Breath Controller Portament Time Volume Expression Sustain Portamento Sostenuto
	5	O	O	
	7	O	O	
	11	O	O	
	64	O	O	
	65	O	O	
Program Change		O (0 - 99)	O (0 - 99)	
	True #	*****	*****	
System Exclusive		O	O	
System Common	: Song Position	X	X	
	: Song Select	X	X	
	: Tune	X	X	
System Real Time	: Clock	X	X	
	: Commands	X	X	
Aux Messages	: Local on/off	X	X	
	: All Note Off	O	O	
	: Active Sense	X	X	
	: Reset	X	X	
Notes: (*1): Varied within a range of -8 ~ +3 depending on the transposition settings. (*2): A fixed value within a range of 1 ~ 127, or variable values by breath control.				

Mode 1 : OMNI ON, POLY Mode 2 : OMNI ON, MONO
Mode 3 : OMNI OFF, POLY Mode 4 : OMNI OFF, MONO

O : YES
X : NO

Trouble shooting

■ No sound !

- Check that the amplifier, mixer or headphones are appropriately connected to the EWI4000s. Refer to the connections section of the manual for additional information. (page 8)
- Check that the EWI4000s is powered on, and that the instrument's batteries are correctly inserted, or the EWI4000s is correctly connected to the proper AC adaptor. Refer to battery and AC adaptor section of the manual for additional information. (page 7)
- Check that the Main Volume level is not set to zero. Refer to adjusting the volume section of the manual for additional information. (page 25)
- Check that the Breath Sensor is appropriately adjusted. Refer to the Breath Sensor adjustment section of the manual for additional information. (page 15).

■ Cannot change the pitch

- Check that the Touch Sensor sensitivity is appropriately adjusted. Refer to the touch sensor sensitivity section of the manual for additional information. (page 18).

■ Endless sound (sound held on)

- Check that the Breath Sensor is appropriately adjusted. Refer to the Breath Sensor adjustment section of the manual for additional information. (page 15)

■ Cannot match the tune with other instrument

- Check that the EWI4000s' tuning function is appropriately set to match other instruments. Refer to the instrument's tuning section of the manual for additional information. (page 34).
- Check that the Bend Sensor is appropriately adjusted. Refer to the adjusting the Bend Sensor section of the manual for additional information. (page 16).

■ Cannot control the sound volume

- Check that the Breath Sensor is appropriately adjusted. Refer to the Breath Sensor adjustment section of the manual for additional information. (page 15)

■ Cannot change the pitch immediately

- Check that the Glide Sensor is appropriately adjusted. Refer to the Glide Sensor adjustment section of the manual for additional information. (page 17).



AKAI professional M.I. Corp.



Printed in Taiwan