

MSD550

MASTER STEREO DISPLAY

USER'S MANUAL

Software Version 3.0
Hardware Version 1.1

DK-AUDIO · Randvolden 23 · DK-2730 Herlev · Denmark
Tel.: +45 44530255 · Fax: +45 44530255

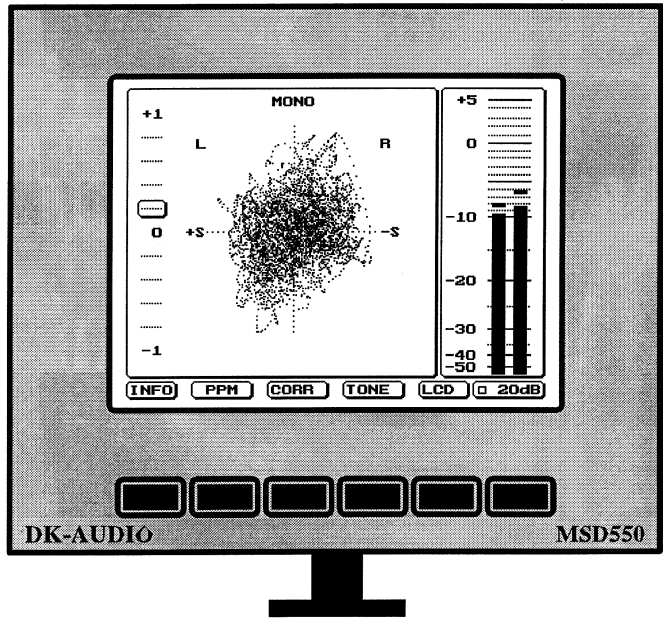
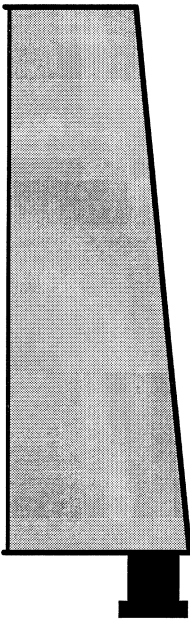

Manufacturer:
DK-AUDIO
Randvolden 23
DK-2730 Herlev, Denmark

CONTENTS

1 INTRODUCTION	7
1.1 About this Manual	7
1.2 About the Master Stereo Display	7
1.3 Inside the Instrument	9
1.4 Precautions	9
2 THE HARDWARE VERSION 1.1	11
2.1 The Audio Input Stages	11
2.2 The Audio Output Stages	11
2.3 The RS-232 Serial Interface	11
2.4 The Power Supply	12
2.5 The CODEC Circuit (A/D and D/A)	12
2.6 The DSP Microcomputer	13
2.7 The System RAM Memory	13
2.8 The EPROM (program storage media)	13
2.9 LCD Display	14
3 INSTALLATION	15
3.1 Mounting Holes	15
3.2 5-pin Power Connector (J1)	15
3.3 9-pin Audio Connector (J5)	16
3.4 Removal of the Connectors	16
3.5 Connecting to the Audio Source	17
4 OPERATIONAL MANUAL VERSION 3	19
4.1 The Main Display and Control Keys	19
4.2 Reading of the Correlation Meter	20
4.3 Reading of the Stereo Display	21
4.4 The Peak Programme Meter	22
4.5 The CCIR 468-3 Quasi Peak Noise Meter	23
4.6 Menu Selection Hierarchy	24

4.6.1 Input Gain	24
4.7 LCD Contrast and Intensity	24
4.8 System Information Page	25
4.8.1 EEPROM Write Protection	26
4.8.2 Serial Number Editor	26
4.8.3 System Reset	27
4.9 Peak Programme Meter Utilities	27
4.9.1 Toggle PEAK Segment	27
4.9.2 Toggle FAST Integration	27
4.9.3 Toggle Peak HOLD	28
4.9.4 Selection of the preferred Scale	28
4.9.5 PPM Setup Menu	29
4.9.5.1 Setting of the TEST LEVEL	29
4.9.5.2 Calibration of the Meter	29
4.10 Correlation Meter	30
5 SPECTRUM ANALYZER PART	31
5.0.1 Spectrum Analyzer DEMO mode	31
5.1 Spectrum Analyzer Menu Level 1	32
5.2 Frequency Cursor Relative Set	33
5.4 Frequency Cursor Move	33
5.5 Spectrum Analyzer Menu Level Two	34
5.5.1 Hold Function	34
5.5.2 Curve Menu	35
5.5.2.1 Temporary Curve Storage	35
5.5.2.2 Permanent Curve Storage	35
5.5.2.3 Relative Display Temporary Curve	36
5.5.2.4 Relative Display Permanent Curve	36
5.5.2.5 Relative Display Pre-emphasis Curve	36
5.5.3 Window Menu	36
5.5.3.1 Rectangular Window	37
5.5.3.2 Hanning Window	37
5.5.3.3 Hamming Window	37
5.5.4 Output Menu	38
5.5.4.1 Select White-noise	38

5.5.4.2	Select Tone Signal	38
5.5.4.3	Tone Generator Settings	38
5.5.4.3.1	Tone Generator Frequency	39
5.5.4.3.2	Output Amplitude Setting	39
5.5.4.3.3	Editing the Frequency Table	39
5.5.4.4	Select Input Signal	40
5.5.5	Input Menu	40
5.5.5.1	Add Left Input	40
5.5.5.2	Add Right Input	40
5.5.5.3	Left/Right Difference	40
6	SOFTWARE UPGRADING	41
7	TECHNICAL SPECIFICATIONS SYSTEM	42
7.1	Power Supply	42
7.2	Mechanical Outlines	42
7.3	Level Meter	43
7.4	Correlation Meter	43
7.5	Stereo Master Display	44
7.6	Tone Generator Output	44
7.7	LCD Display	44
8	REGISTRATION CARD	45
A.	LAYOUT DIAGRAM	47
B.	MENU SELECTION HIERARCHY	48

1 INTRODUCTION

1.1 About this Manual

This manual is divided into seven sections:

- *part one: introduction*
- *part two: hardware*
- *part three: installation*
- *part four: standard software*
- *part five: spectrum analyzer software*
- *part six: upgrade information*
- *part seven: technical specification*

The instrument hardware is fixed at the date of supply whereas the software can be updated later on. It is important to compare the instrument's current software release number before using this manual.

A drawing of the *menu selection hierarchy* is included in the back of this manual.

1.2 About the Master Stereo Display

The Master Stereo Display can be used as the master meter of any mixing desk. It displays the stereo information and the stereo program level at the same time, provides the recording engineer with the maximum information about the recorded signal.

The characteristics of the PPM can be selected from soft keys, and all international standards are supported. The input reference level is selectable, together with an additional 20 dB of input gain.

All processing is digital and ballistic, and scale errors are virtually eliminated.

A non-volatile memory chip will store all user defined parameters.

The version 3 software also includes a spectrum analyzer which enables comprehensive analysis of an audio signal. Test options includes:

- *audio spectrum analysis*
- *distortion (THD, IM)*
- *transfer response*
- *noise analysis*
- *room accustics*
- *difference curve measurements*

The utilization of the stereo output has been increased and is now including:

- *low distortion tone generation*
- *true white-noise generation*
- *input monitoring*

The system is fitted with a RS-232/V.24 serial port for external computer connection, and the Master Stereo Display has the following options:

- *line test option EBU R27/CCITT O.33*
- *burst generator option*
- *ASCII display of external data*
- *downloadable software from host computer via RS-232*
- *screen dump utility via RS-232*

The LCD has a very high contrast ratio and viewing angle and the lifetime of the CCT backlight is more than 10 years in normal use.

1.3 Inside the Instrument

Important: Before removal of the housing disconnect the power supply and never attach the power supply when the housing is removed.

You need to open the instrument in order to alter the power supply connection, audio and the optional data circuit or update the software (1, 1).

Before removal of the housing, unscrew the two outmost screws in the bottom of the case.

Leads are fixed into their position with a 4 mm blade screwdriver. Note that the terminal blocks can be removed completely by gently pulling on the edges. See installation section.

1.4 Precautions

- (a) Never operate the unit while opened, as high voltage (600 V AC) applied to the LCD background illumination is dangerous.
- (b) Avoid getting the unit wet or humid, since water will create leakage currents on the board which may damage the electronic circuitry.
- (c) The polarizer in front of the LCD is quite susceptible to scratches. Handle very carefully. Do not press or rub.
- (d) Do not contact the display surface or stain it. If the surface is dirty, wipe it lightly with a cotton swab (or a piece of soft cloth or chamois) which is soaked with petroleum or benzine. Never use organic solvents (including acetone, toluene, ethanol and isopropyl alcohol), they will

damage the surface.

(e) Do not allow water or other liquids to remain on the surface for long. This may cause a local deformation or discolouration.

(e) If the LCD breaks, and the liquid crystal runs out, keep well clear of the mouth and eyes. If it sticks to the skin or clothes, wash it off immediately with soap and water.

2 THE HARDWARE VERSION 1.1

In this chapter, we take a look at the components of the Master Stereo Display in some detail.

2.1 The Audio Input Stages

The display has dual transformer-coupled input stages, which works independently. Due to this special design there is no return influence on the feeding audio lines, and the input impedance will remain constant without power. The performance of the analogue stages is so excellent that the unit can be used to test external circuits.

2.2 The Audio Output Stages

The unit has two unbalanced audio outputs. They can be used in either mono or stereo mode depending on the installed software. With version 3 software both outputs will carry the same signal except in the input monitoring mode. The maximum output drive current is 30 mA RMS and 10 dBu and is capable of driving a headphone at normal listening level.

2.3 The RS-232 Serial Interface

The serial interface form a full duplex data channel running at a maximum of 9600 baud. No hardware handshake signals are provided. The port is used to communicate with an external system, or to download software from an external PC. The function is not utilized in the version 3 software.

2.4 The Power Supply

The power supply is based on the linear regulation principle and accepts both AC and DC input. The inputs are connected to a full-wave rectifier and therefore the assignment of the positive and negative terminals from a DC supply are free.

Recommended supply voltages are 9V AC 50Hz or 12V DC.

High voltage for the LCD background lighting is generated by the attached PCB. Special care must be taken in a maintenance situation as 500 V AC is present on this PCB.

2.5 The CODEC Circuit (A/D and D/A)

The CODEC circuit integrates the key audio data conversion and control functions into a single integrated circuit. Anti-alias and anti-imaging filters are incorporated on-chip. Dynamic range and signal-to-noise will typically exceed 80 dB over the 20 kHz audio band. Sample rates from 8 kHz to 48 kHz are supported, but with the current software it is fixed to 48 kHz.

The CODEC includes a pair of $\Sigma\Delta$ analogue-to-digital converters (ADCs), and a pair of $\Sigma\Delta$ digital-to-analogue converters (DACs). Gain can be controlled independently for each channel.

The $\Sigma\Delta$ DACs are preceded by a digital attenuator and a digital interpolation filter. Nyquist images are removed from the DAC's analogue stereo pairs by on-chip switched-capacitor and continuous-time filters.

2.6 The DSP Microcomputer

The ADSP-2115 is a single chip microcomputer optimized for digital signal processing (DSP) and other high speed numeric processing applications. The computer has 512 words of (16-bit) data memory RAM and 1K word (24-bit) program memory RAM on chip. It runs with an instruction cycle of 80 ns.

2.7 The System RAM Memory

The system has 16K words (16-bit) data memory RAM and 16K words (24-bit) program memory RAM externally fitted. The program memory can be used for data or program storage. The access time to the memory circuit is 25 ns.

2.8 The EPROM (program storage media)

All software is stored in the removable EPROM circuit. When the Master Stereo Display is supplied with new features, it will normally be necessary to replace this chip.

The EPROM is only active during program loading, all real-time computation takes place either internally in the DSP, or in the fast external RAM chips.

2.9 LCD Display

The module is a dot matrix display (NTN, Super Twist) displays graphics 320 dots horizontal and 240 dots vertical. The display has a Cold Cathode Tube Unit installed inside the module for background illumination. The display is controlled directly from the DSP.

The contrast voltage applied to the LCD is controlled from the DSP and temperature compensated.

3 INSTALLATION

Carefully read this part of the manual before you apply power to the instrument for the first time.

Please compare all connections with the printed text on the PCB below the connectors.

All references refer to the layout diagram in appendix A.

3.1 Mounting Holes

The unit should be secured to the working surface with two (4 mm) metal or wood screws in order to provide a stable platform. The distance between the fixing holes is 22 mm.

3.2 5-pin Power Connector (J1)

Please note: The connector can be removed.

9V AC input/8-17V DC	AC	1
9V AC input/8-17V DC	AC	2
Chassis / Ground	GND	3
RS-232 transmit	TX	4
RS-232 receive	RX	5

If required, connect protective earth to terminal 3.

3.3 9-pin Audio Connector (J5)

Please note: The connector can be removed.

Output reference	GND
Left channel output	M+
Right channel output	M-
Left channel screen	GND
Left channel phase	L+
Left channel ref.	L-
Right channel screen	GND
Right channel phase	R+
Right channel ref.	R-

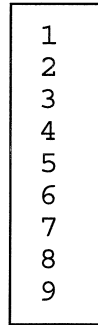

3.4 Removal of the Connectors

The terminal blocks can be removed from the PCB with a vertical pull. Be careful to engage correctly otherwise permanent damage will be caused to the electronic circuitry.

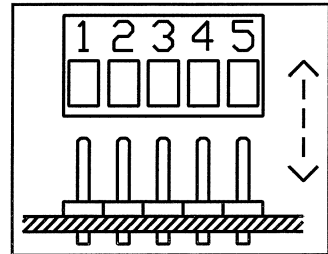

3.5 Connecting to the Audio Source

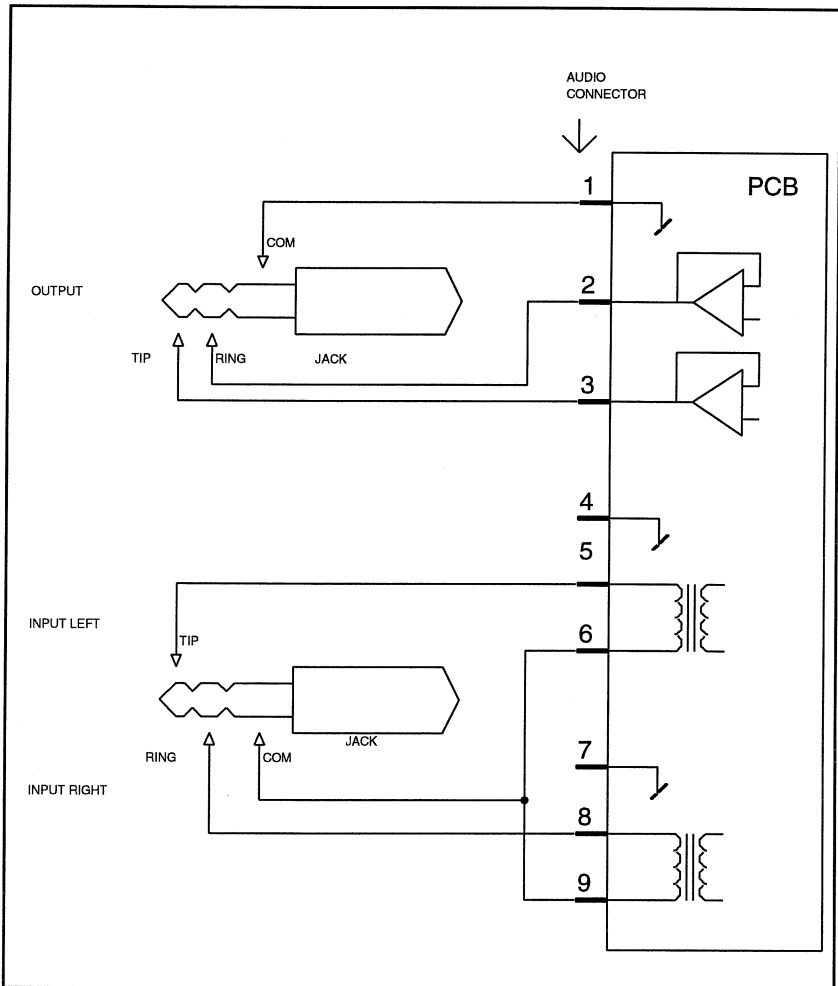

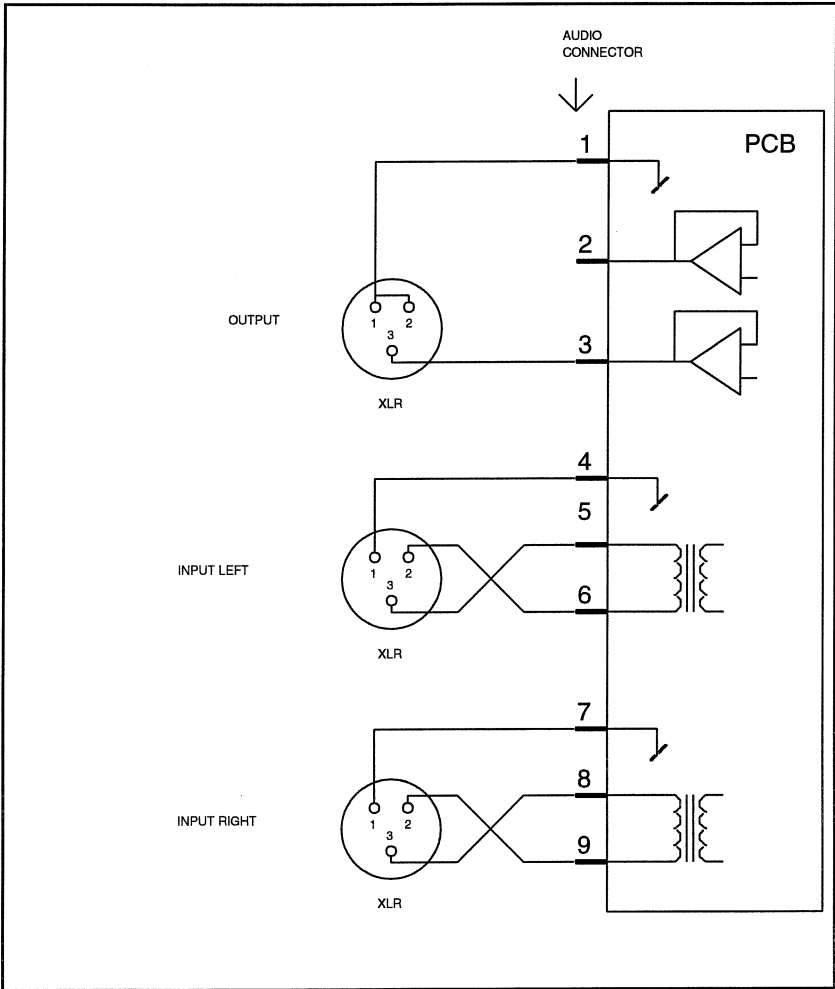

4 OPERATIONAL MANUAL VERSION 3

The system contains user modifiable system configuration and internal system configurations in an EEPROM (Electrical Erasable PROM). Each time the system is powered-up, the microcomputer reads the EEPROM in order to re-engage the default previous set-up.

The power-up default settings are write-protected by the **W-PROT** function in the **INFO** menu.

4.1 The Main Display and Control Keys

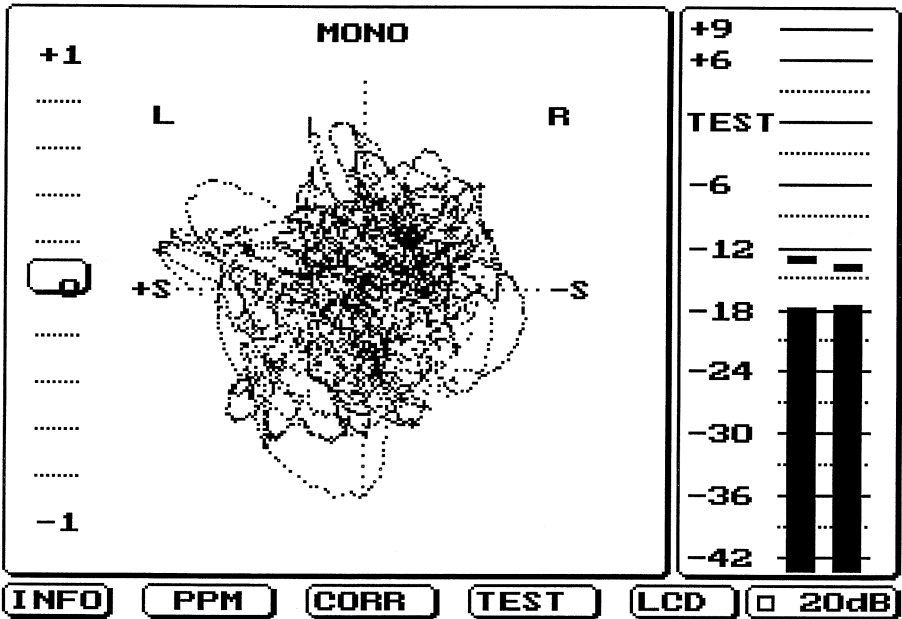

The six keys below the LCD are assigned to the function displayed in the *Menu Selection* area. Holding a key down will, after a short delay, repeat the function.

The main display area is sub-divided into four areas:

- *Correlation Meter*
- *Stereo Phase Display*
- *Peak Programme Meter*
- *Menu Selection*

Appendix B is a complete diagram of the menu selection hierarchy.

4.2 Reading of the Correlation Meter

The correlation meter displays the phase relationship between the two input signals. A stereo signal will ideally show '0', which is random distributed phase, and thus the maximum ambient effect. Mono will indicate '+1' and a signal with reversed phased components will indicate in the range '0' to '-1'. *Never allow negative indication if the signal is going to be used in mono.*

Indication

+1	Mono Signal (in Phase)
0	Ideal Stereo Signal No signal Left or Right Signal only
-1	Reverse Phased Components

Input signals below a predefined threshold will force the indication

towards zero. Only major phase components are considered.

4.3 Reading of the Stereo Display

The stereo display provides information on the phase and amplitude distribution in the signal. If phase and amplitude is randomly distributed, the signal is an ideal stereo signal. Normally, this will only be the case for a live recorded signal. A live recorded audience applauding gives you an excellent example of a true stereo signal.

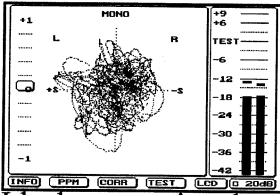

Ideal stereo signal

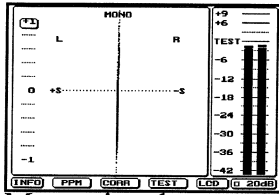

Mono signal

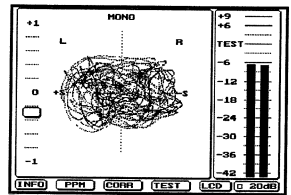

Reverse phased
stereo signal

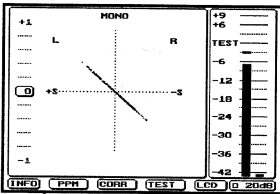

Left signal

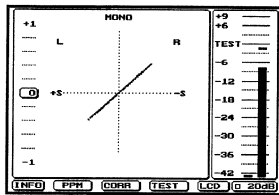

Right signal

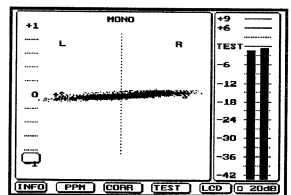

Reverse phased
mono signal

Note the relationship between the indication of the correlation meter and the phase oscilloscope pattern.

4.4 The Peak Programme Meter

The peak programme meter is designed for direct measurement of the quasi-peak level of complex electrical signals occurring in the transmission of music or speech, without varying the sensitivity of the device, to achieve an optimum technical utilization of the transmission channel, or of the recording medium.

For this purpose, a full-wave rectifier is used and the integration time is chosen so as to obtain an amplitude as high as possible without overloading the transmission link for a period long enough to give rise to audible non-linear distortion of the programme. The return time is relatively long in order to avoid unnecessary observer fatigue.

The Master Stereo Display version 3 supports the PPM's called for in the IEC 268-10, IEC 268-17 and the DIN 45406.

PPM features:

- *Selectable Scale*
- *Fast Peak Detection*
- *'Flying' Peak Segment*
- *Peak Hold / Fast Peak Hold*
- *Reference Level Selection*

Drawings of the supported scales can be found in section (4.9.4).

4.5 The CCIR 468-3 Quasi Peak Noise Meter

The measurement method of audio-frequency noise voltage level in broadcasting, sound-recording systems and sound-programme circuit has been standardized by the CCIR. The noise voltage level is measured in a quasi-peak and weighted manner, using a weighting network and a quasi peak rectifier. The ideal weighting network is shown below.

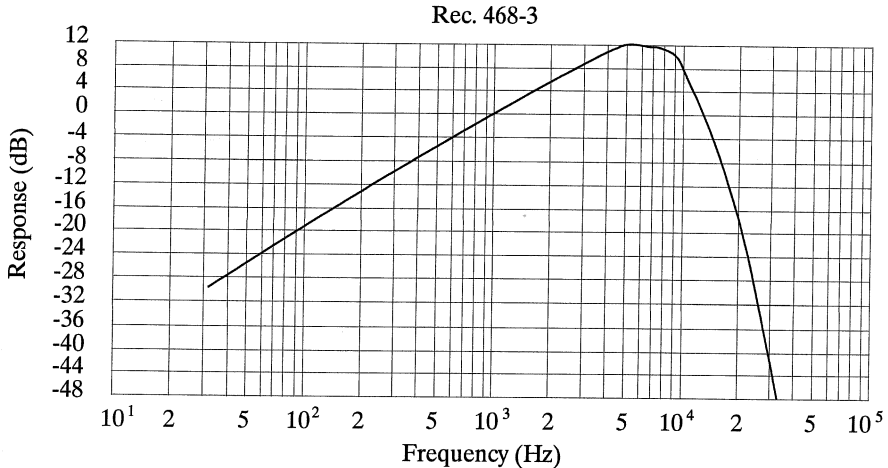

Please note. Due to the limitations of the digital sampling system frequencies above the system bandwidth are removed. This will not have an influence on the actual reading of the noise.

Always use the dBq scale with the **20dB** gain selection in order to obtain the best possible dynamic range and accuracy.

While selected the update rate of the phase oscilloscope is reduced. This will not have an influence on the noise reading.

4.6 Menu Selection Hierarchy

The complete selection menu hierarchy is included as appendix B.

The **EXIT** key will always engage the previous menu level.

Keys may have a 'LED' like the **W-PROT**. The dark marking is indicating a active function. In this case the EEPROM write-protection is on.

Note: The power-up default settings are protected against unintentional over-writing as long as the write-protection is on.

4.6.1 Input Gain **20dB**

The input sensitivity can be increased by 20 dB by pressing the **20dB** key. The function is used when measuring the noise in a circuit.

Note: The automatic long-term contrast adjusting procedure is disabled when the function is selected. Therefore it is not recommended to leave the meter with the additional gain selected.

4.7 LCD Contrast and Intensity **LCD**

Enter the LCD utility menu by pushing the **LCD** key. These settings would not normally need changes. The contrast voltage applied to the LCD is modified with the **CONT ↑ 20 ↓** keys, and the background lightning with the **↑ 20 ↓ INTS** keys. Please note the normal settings for the instrument.

A filter is used in the adjustment of the internal control voltages. Allow 10 seconds for the control to stabilize before adding another step.

Changes are only recorded in the power-up default settings if EEPROM writing is enabled (4.8.1).

4.8 System Information Page INFO

The system information page displays important hardware- and software-dependent information. Display this page if there is any doubt about the installed options.

DK-AUDIO, DK-2730	+9 _____
TEL +45 4453 0255	+6 _____
FAX +45 4453 0367
METER REFERENCE: 1.55V	TEST _____
SOFTWARE VER. : 3.1
HARDWARE VER. : 1.1	-6 _____
TONE GENERATOR : INSTALLED
TEST INSTRUMENT : NOT INST	-12 _____
SERIAL NUMBER : 00215
FFT ANALYZER :▶ 19221	-18 _____

	-24 _____

	-30 _____



	-36 _____

	-42 _____

EXIT ▣ W-PROT NEXT ↑ ↓ ▣ RESET

4.8.1 EEPROM Write Protection

When the system is powered-up the EEPROM write-protection is allways on. If the default settings need changes the write-protection must be removed otherwise changes are considered to temporary and will not be restored the next time the system is re-powered.

The  is also controlling the apperence of the  selection key in the PPM utility menu (4.9.5.1). The  key is visible when writing is enabled.

It is recommended to leave the write-protection on at all time.

4.8.2 Serial Number Editor

The serial number editor is used to enter the license number of the spectrum analyzer option. Please contact your local dealer or Danish Pro Audio ApS (+45 4814 2828) to obtain the license number.

The next key will move the cursor to the next entry field and the arrow up and down will edit the number. Follow the procedure listed below:

- 1) Remove the write-protection (4.8.1)
- 2) Move to the desired field with the next key
- 3) Edit the the number with up and down keys
- 4) Put write-protection back on
- 5) Re-power or follow the reset procedure (4.8.3)

4.8.3 System Reset RESET

Pressing the reset key will 'arm' the reset function. The system reset will take place immediately when the EXIT is pressed. The reset function is identical to a normal power-on reset. System reset is only used when a licence number has been added to the license number list (4.8.2).

4.9 Peak Programme Meter Utilities PPM

Enter the PPM utility menu by pressing the PPM key. From the PPM menu the 'flying' PEAK segment is turned on and off. You can also select the FAST integration mode and peak HOLD mode. Active options are indicated by the 'LED'.

From SCALE menu the preferred scale is selected.

4.9.1 Toggle PEAK Segment PEAK

When enabled, the three upper most bar-graph lines are 'left' flying for approximately two seconds indicating the top of the bar value. During the peak hold period, a new shadow peak value is recorded. This value will become the next peak indication. Both channels work independently.

4.9.2 Toggle FAST Integration FAST

In the 'fast' mode the integration time is set to zero. The bar-graph therefore indicates the peak value of the input signal. Please note: with a steady sinusoidal input signal, the bar-graph indication is the same

whether 'fast' is enabled or not.

4.9.3 Toggle Peak HOLD HOLD

In the 'hold' mode, the flying segment will indicate the highest bargraph value since the last hold reset. Hold reset is performed by re-selection of any function or scale.

4.9.4 Selection of the preferred Scale SCALE

Five international scales are supported. Please study the IEC 268-10 Peak Programme Level Meters, the IEC 268-17 VU meter, the DIN 45406 and the IRT Pflichtenhefte 3/6, the Nordic N9, CCITT Recommendation J.15, CCIR Report 292-2 and BS6840 part 10 to obtain the complete set of specifications.

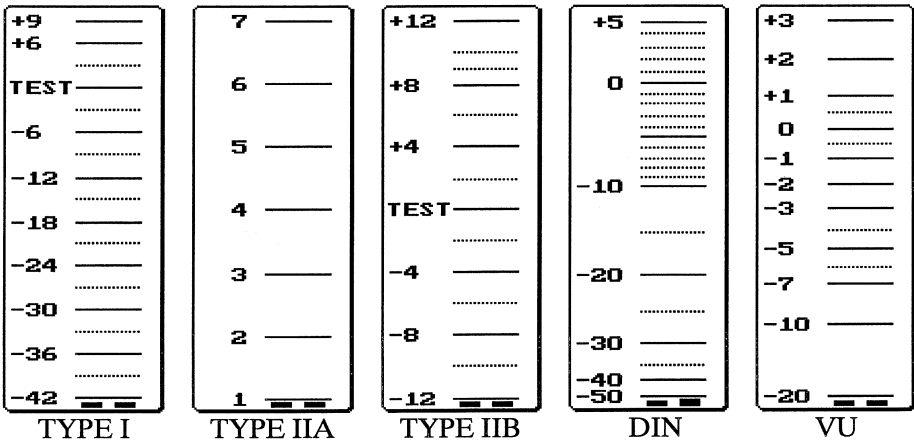

The TYPE I, TYPE IIA, TYPE IIB and the DIN scale have the same integration time.

4.9.5 PPM Setup Menu **SETUP**

The PPM setup menu will configure the PPM test level and align the meter. The function is only selectable if the **W-PROT** is off (4.8.1).

Important: Any changes made with the write-protection off will permanently change the reference point of the PPM.

4.9.5.1 Setting of the TEST LEVEL **↑ +0 ↓**

Use the arrow up and down keys to modify the input test level.

Note: Test level 0 dBu (0.775V RMS) is standard.

4.9.5.2 Calibration of the Meter **CALIBRATE**

Use these functions only to re-calibrate the instrument, as changes will overwrite calibration factors in the internal EEPROM. Apply the desired reference level to the input terminals, and use the appropriate arrow key to adjust the bar-graph height. It is recommended to disable the **PEAK** function during calibration.

Use either the built-in test tone-generator (5.5.4.3) output on connector block (3.3) or an external 1 kHz reference tone (0 dBu).

Press **UPDATE** to make the changes permanent in the internal EEPROM, or **QUIT** to leave the calibration menu unchanged.

4.10 Correlation Meter **CORR**

The velocity of the indicator is selectable. Select either **SLOW FAST** mode depending on personal preference.

5 SPECTRUM ANALYZER PART

Most spectrum analyzers for sound engineering are based on analogue filtering technique. For many years this has been the only practical solution for real-time analyzers having a sensible size and cost. Modern signal processors like the MSD550 has made it possible to implement the complex FFT (Fast Fourier Transformation) algorithm, which outperform its analogue counterpart by many length. The number of frequency bands are increased from the traditional 27 to 1024 and the dynamic range to 80 dB. These enhancements makes it possible to analyze noise, distortion (IM), frequency response and much more in a new more detailed way.

The system utilizes analysis both left or right channel, the mono signal and difference signal. Furthermore a permanent memory array will hold a reference curve which can be used to compare measuring results.

The spectrum analyzer part also contains a digital tone- and white-noise generator.

A peak hold function has been implemented for storage of a audio spectrum.

5.0.1 Spectrum Analyzer DEMO mode

DEMO mode. When the version 3 software is installed for the first time, the Spectrum Analyzer will work weather the license number is entered or not. Each time the **TEST** keys is activated a counter is decremented, and when the counter reach zero, the word DEMO appear in the left hand corner. Then the function of the analyser is limited and can only

be activated by the correct license number (4.8.2).

The initial count for each unit is set to 40-50 times.

5.1 Spectrum Analyzer Menu Level 1 **TEST**

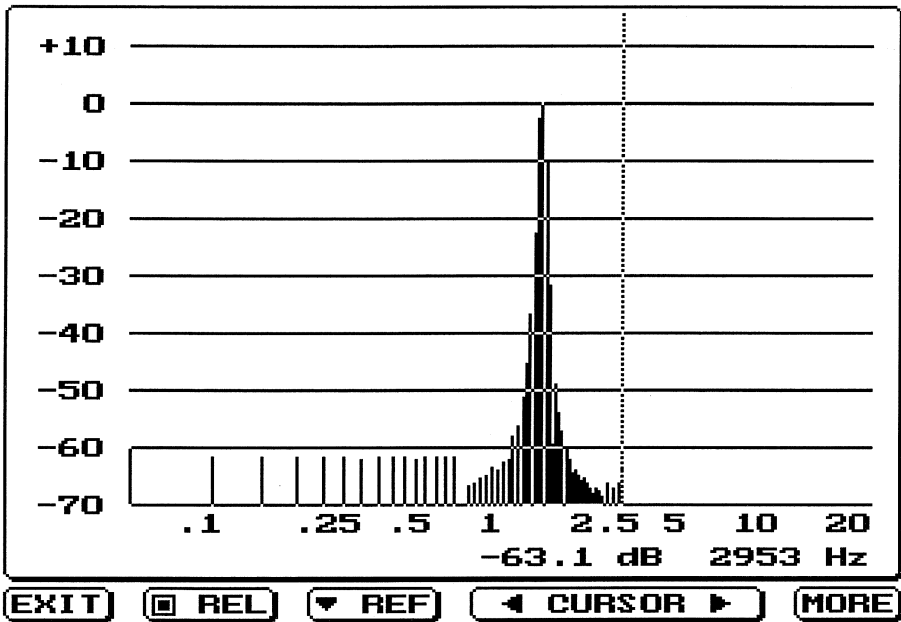

The menu level 1 is especially useful in harmonic analysis of an input signal. With the set reference and display relative functions measuring results are easily obtained from the numeric display field.



Any harmonic or intermodulation distortion developed by the audio channel is immediately identified in this window. On the screen dump the frequency components of a 1.5 kHz taken from the internal digital oscillator is analyzed. With the **REF** key the level fundamental tone is recorded and the **REL** with offset the complete curve in respect to the reference signal. The cursor is pointing at the 2nd harmonic

frequency and is reading -63.1 dB. The lowest readable level is approximately -70 dB below reference.

5.2 Frequency Cursor Relative Set

The function work together with the display relative function (5.3). With the  the curve readings can be normalized to the reading at cursor. If the display relative is active the complete curve is shifted up or down until the cursor reading is zero. The  key will only manipulate the on-screen data and should only with care be used to raise a weak input signal since accuracy is lost. Instead the input sensitivity should be raised with the  or the test level should be increased.

The numeric readout will allways follow the graph.

5.3 Frequency Cursor Relative Display

The display relative function is used in conjunction with the set relative function (5.2). The function will toggle between a absolute and a relative readout for both the graph and the numeric readout.

5.4 Frequency Cursor Move

The arrow keys will move the frequency cursor up or down. While holding the key down the speed of the cursor movement is increased by a factor of ten. Exact placement of the cursor is done with individual keystrokes.

The numeric fields shows the cursor level and frequency.

Notes: The resolution of the spectrum analyzer is higher than the screen resolution. Consequently not all analysis results are displayed. The frequency cursor can be used to obtain the 'hidden' data since it will display the complete set of data.

5.5 Spectrum Analyzer Menu Level Two MORE

Menu level two provide more data manipulation functions, analogue input and output control. At this menu level the frequency cursor is not displayed.

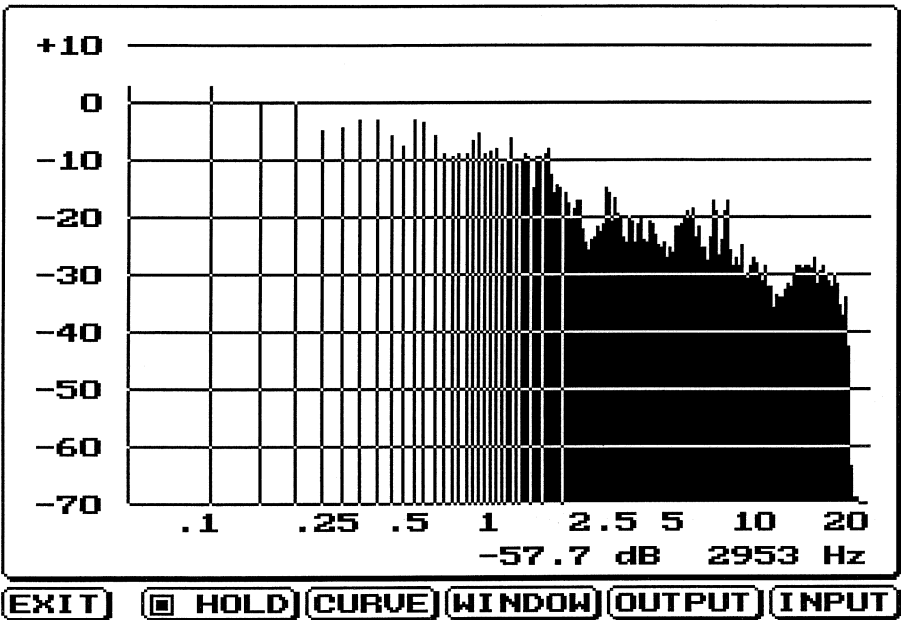

5.5.1 Hold Function HOLD

The hold function will disable the display fallback function and thus show the maximum value since the hold was activated.

5.5.2 Curve Menu **CURVE**

The curve menu is used to display the spectrum analysis relative to a temporary or predefined reference curve. The relative display functions can all be active at the same time.

5.5.2.1 Temporary Curve Storage **REF**

This function is used to store a curve temporarily in order to show the difference curve with the display relative function (5.5.2.3). The curve currently on screen will be memorized. The memorized curve is reset to 'flat' response everytime the spectrum analyzer is terminated.

The function is usefull for accoustic testing of rooms, speakers etc.

5.5.2.2 Permanent Curve Storage **MEM**

This function is used to store a curve permanent in the EEPROM in order to show the difference curve with the display relative function (5.5.2.4).

The curve currently on screen will be memorized. The memorized curve is recalled when ever the spectrum analyzer is engaged.

The save function is sensitive to the write-protection (4.8.1). If write-protection is on the **MEM** can be used for temporary storage.

The function is usefull for accoustic testing of rooms, speakers etc.

5.5.2.3 Relative Display Temporary Curve **REF**

Add the temporary curve storage (5.5.2.1) to the the current audio spectrum.

5.5.2.4 Relative Display Permanent Curve **[O+MEM]**

Add the permanent curve storage (5.5.2.2) to the current audio spectrum.

5.5.2.5 Relative Display Pre-emphasis Curve **[O+PRE]**

The pre-emphasis is ‘lifting’ the data readout with 3dB/octave, resulting a visual appearance as a 1/3 octave analyzer.

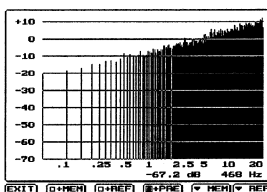

This lift provided a closer relationship between the aural and the visual judgement of a music audio spectrum.

5.5.3 Window Menu **[WINDOW]**

Since the spectrum analyzer is based on the Fast Fourier Transformation principle the sampled audio data need *windowing*. An in dept mathematical explanation is not the scoop for this manual and should be retrieved from technical literature.

The audio is sampled with 48 kHz and entered in a digital buffer having the length of 1024 entries. This amount of audio samples is then analyzed and displayed. While calculating the FFT a new set of data is recorded. No data is lost.

Since the 1024 samples used for the calculation is a *window* of the continues audio samples the beginning and the end of the 1024 need

some smoothing in order not to develop erroneous results. The data needs windowing.

The system is implemented with three different window functions. The recommended window function for most applications is the **Hanning** (5.5.3.2) window.

5.5.3.1 Rectangular Window REC

In the rectangular window function all samples are multiplied with one. This window function is nearly a method of disabling windowing of the data. **The rectangular window provide the highest selectivity, but the lowest dynamic range.**

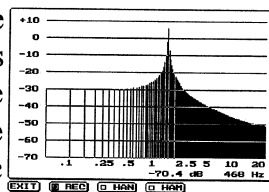

5.5.3.2 Hanning Window HAN

The Hanning window is usefull in most applications and should be selected as default.

The Hanning window provide the highest dynamic range, but the lowest selectivity.

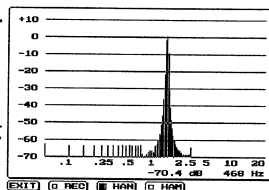

5.5.3.3 Hamming Window HAM

The Hamming window is ideal for applications where the requirement to the dynamic range is known.

The Hamming window compromise between

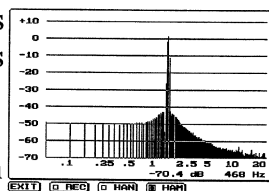

selectivity and dynamic range.

5.5.4 Output Menu OUTPUT

From the output menu the stereo analogue outputs are controlled.

5.5.4.1 Select White-noise NOISE

The version 3 software can generate a true random white-noise signal usefull for testing of frequency response of a electronic circuit or acustic system. Per definition a white-noise contains all frequencies at equal energy. The spectrum of the noise signal is limited to the audio range by the sampling system and the analogue output stage.

A white-noise signal will provide a flat frequency spectrum on a FFT-based analyzer since the analyzer 'filter' bandwidth is constant.

5.5.4.2 Select Tone Signal TONE SETUP

This function will enable or disable the low distortion digital tone generator.

5.5.4.3 Tone Generator Settings TONE SETUP

The tone generator is driving both outputs with the same signal, but each output driver is separate.

The tone generator settings will be stored in the EEPROM power-up default area if the write-protection is removed (4.8.1).

5.5.4.3.1 Tone Generator Frequency

With the arrow left and right keys the output frequency is set according to a user-definable frequency table stored in the EEPROM. The frequency table has 27 entries. From the **EDIT** menu (5.5.4.3.3), the frequency table values can be customized.

5.5.4.3.2 Output Amplitude Setting

With the arrow up and down keys the output amplitude for the tone generator is set in dBu according to a predefined 1 dB table.

If white-noise (5.5.4.1) is selected the output amplitude is relative and not absolute.

When the input signal (5.5.4.2) is selected, the maximum output level is automatic selected in order to provide the best possible signal/noise ratio.

The range is +10 dBu to - 6 dBu for the sine output level.

5.5.4.3.3 Editing the Frequency Table **EDIT**

Edit the output frequency with the arrow keys  and save the entry with the **SAVE** or leave without an update with the **QUIT**.

Note: The write-protection (4.8.1) must be removed in order to alter the frequency tabel.

5.5.4.4 Select Input Signal INPUT

This function will ‘echo’ the input signal to the stereo output. The function is used to monitor the audio signal provided to the meter.

The output level can not be controlled (5.5.4.3.2).

The function is not selectable in DEMO mode (5.0.1).

5.5.5 Input Menu INPUT

From the input menu the analyzer input signal is defined.

5.5.5.1 Add Left Input LEFT

Add left input to the analyser. Note selection of both left and right input will increase the input amplitude to the analyzer.

5.5.5.2 Add Right Input RIGHT

Add left input to the analyser. Note selection of both left and right input will increase the input amplitude to the analyzer.

5.5.5.3 Left/Right Difference L-R

Use this function to display the difference between two signals. Both left and right must be active for the function to work correctly.

6 SOFTWARE UPGRADING

Carefully follow the following steps:

- 1) Insert the supplied EPROM chip as described in section (1.3, 2.8). Be carefull to place the chip correctly.
- 2) Enter the appropriate the licence number (4.8.2).

If the unit fail to operate immidiately turn of the power and contact your local dealer.

7 TECHNICAL SPECIFICATIONS SYSTEM

7.1 Power Supply

Supply voltage range,	a) DC input	: +8V to +17V
	b) Mains adapter	: 220VAC+/-10%
	c) Mains adapter UK ver.	: 240VAC+/-10%

DC current consumption, @ 12V nominal supply	: <600 mA
Power Dissipation, approximately	: 6.5 W
Safety according to	: IEC 65

7.2 Mechanical Outlines

Width	: 155 mm
Height, case alone	: 132 mm
Depth	: 45 mm
Connectors, screw terminals - removable	: 5+9 pins

7.3 Level Meter

Reference indication		: 0 dBm
Reference input voltage		: 1.55 V
Reference input voltage adjustment range		: +3 dB to -6dB
Division of scale	a) DIN 45406	: -50 dB to +5dB
	b) IEC 268-10, TYPE I	: -42 dB to +12dB
	c) IEC 268-10, TYPE IIa	: -12 dB to +12dB
	d) IEC 268-10, TYPE IIb	: 1 to 7
	e) IEC 268-17, VU Scale	: +3 dB to -20 dB
	f) CCIR 468-3	: +10 dB to -50dB
Amplitude-frequency response, 30 Hz to 20 kHz ¹⁾		: ± 0.3 dB
Dynamic response	a) Pflichtenheft 3/6	: 3 ms / -3 dB
	b) IEC 268-10	: 5 ms / -2 dB
	c) CCITT	: 5 ms / -2 dB
	d) IEC 268-17 (VU)	: 300 ms
Overswing		: none
Return time	a) Pflichtenheft 3/6	: 20 dB / 1.5 s
	b) IEC 268-10	: 20 dB / 2.0 s
Reversibility error		: none
Input impedance, transformer		: > 20 kΩ
Distortion introduced by the PPM		: none
Temperature range		: 0° C to 45° C
Overload characteristics		: > +15 dBu
Maximum input level		: 90 V RMS cont.

¹⁾ Not valid for CCIR 468-3

7.4 Correlation Meter

Indication range		: -1 to +1
Display modes		: Fast/Slow mode

7.5 Stereo Master Display

Automatic gain adjusting range	: 30 dB, default
Phase error between channels	: none
Display area	: 78 mm x 78 mm

7.6 Tone Generator Output

Frequency range	: 33 to 21600 Hz
Level range	: -6 to +10 dBu
Distortion, @+6 dBu 1kHz, BW 20 kHz	: \leq -60 dB
Frequency response flatness	: \pm 0.3 dB

7.7 LCD Display

Resolution	: 320 x 240 dots
Pixel size	: 0.27 mm
Contrast ratio	: typ. 11
Viewing area	: 102mm x 78mm
Viewing angle	: 90 CR>3
Backlight, white, Cold Cathode Fluorescent Tube	: CCFT
Lifetime CCFT, cont. driving, 50% intensity	: typ. 15000 hrs.
LCD surface brightness	: typ. 45 cd /m ²
Backlight adjustment range	: 65 %

8 REGISTRATION CARD

Please fill in the registration card and send it to the address given below to obtain the latest information about software options released.

Name: _____

Company: _____

Address: _____

Phone: _____

Fax: _____

Hardware release: _____

Software release: _____

Serial number: _____

What features would you like to see in future versions of the software?

Mail or fax to:

DK-AUDIO

Randvolden 23

DK-2730 Herlev

Denmark

PHONE: +45 44530255 FAX: +45 44530367

A. LAYOUT DIAGRAM

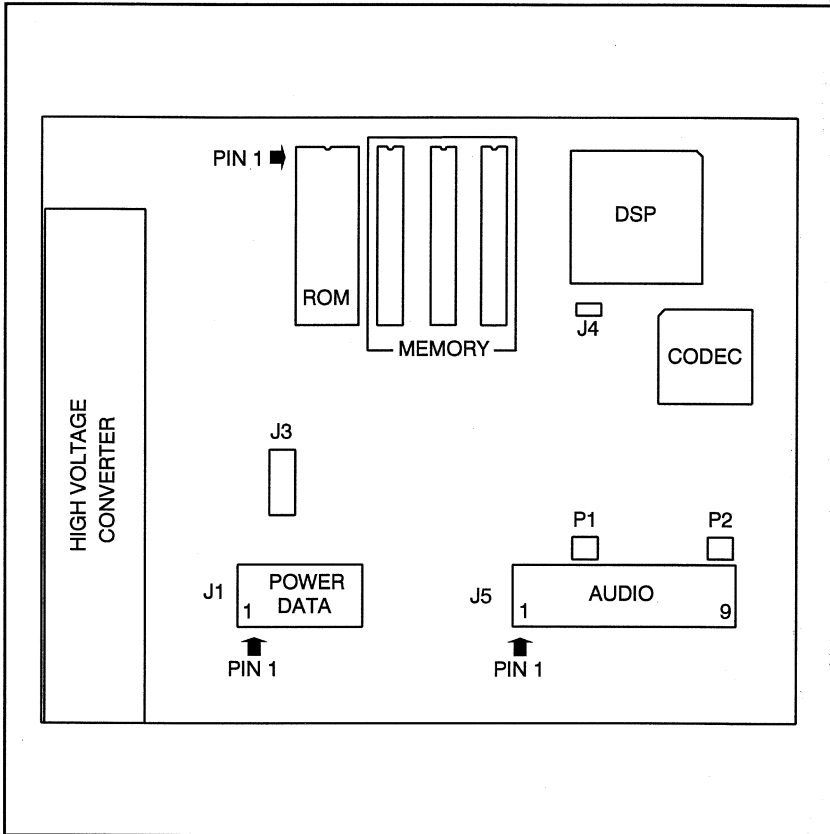

Main PCB Layout

B. MENU SELECTION HIERARCHY

